

**Compact
and
Versatile**



The XL 400 Street Thunder Light Bar Control Panel operates simply, with easy to use push-button style switches. The program options add a new dimension to light bar control.

**Please read entire instruction manual *prior* to starting the
XL 400 Street Thunder Switch Panel Installation.**

Special Features and Applications

Stealth Switch

'Go Dark' - ALL LIGHTS OFF instantly, but ready for action when needed.

Intersection Switch

Let other drivers know you are there!
Pursuit lights and siren are turned ON only while driving through the intersection.

Timed Gun-Lock Switch

Save money! Don't buy expensive timing relays. Open any gun-lock using the unique timer option in this switch.

Pursuit Slide Switch

Easy to use... Just move the 3-position slide switch to pursuit ONE, TWO or THREE.
Easy to install. Choose one of the pursuit program options and simplify the installation.

Walk-Around-Test

Save time! Shift check-ins are easy when your lights turn ON automatically as you walk around the vehicle checking light bulb status.

Ignition Master OFF

Protect the alternator from a 'Load Dump' failure! Ignition OFF, sequentially turns OFF all lights.

Switched Master OFF

One switch controls all lights On - Off, plus protects the alternator from a 'Load Dump' failure.

Blown Fuse Indication

Know instantly when a fuse blows! Each switch affected turns on a warning light.

Contents

Special Features and Applications	Page 1
Contents, Specifications, Installation Tools, Technical Support	Page 2
Component Parts List	Page 3
Operation: Light Bar Control Panel	Page 4
Planning: Light Bar Switch Programming	Page 5
Programming Details: Push Button Switches	Page 6, 7
Installation: Bracket and Panel	Page 8
Electrical Installation: J1 Logic Power	Page 9
Testing: Logic Power	Page 10
Installation: High Current Power	Page 10
Electrical Installation: Switch Outputs	Page 11
Planning: Pursuit slide Switch Program Details	Page 12
Sample - Pursuit Relay Installation	Page 13
Programming: Pursuit Switch	Page 14
Electrical Installation: Pursuit Relays	Page 14, 15
Testing: Pursuit Relay	Page 15
Testing: Final Checkout	Page 15
Trouble Shooting Guide	Page 16, 17
Special Application Installation Diagrams	Page 18
Limited One (1) Year Warranty	Page 19
Blank Page (Installation Notes or Diagrams)	Page 20

Specifications**Electrical:**

Switches 1 & 2:	20 Amps each, Maximum combined current - 30 Amp fuse in panel
Switches 3, 4, & 5:	20 Amps each, Maximum combined current - 30 Amp fuse in panel
Switch 6:	30 Amps - Maximum current - 30 Amp fuse in panel
Pursuit Switch:	30 Amps each position (circuit protection not provided)

Physical:

Panel:	6 ½" x 2 ½" x 2 ½" (width, height, depth)
Bracket:	6" x 1 ½" (width, depth)

Illumination:

Switches 1-6:	Status and location
Pursuit Switch:	Status
Lens Function:	Location

**Installation Tools**

Voltmeter, analog or digital
 Phillips Screw Driver
 Adjustable Wrench
 #8 Hex Head Screw Driver
 #10 Hex Head Screw Driver
 Wire Cutter
 Wire Stripper
 To Clean Grounding Pad: Scraper, Sand Paper, Alcohol Based Cleaner

Technical Support

Visit the factory website to download a copy of these instructions, e-mail technical questions and see other TouchTronics, Inc. Products.

Phone Numbers

Galls, Inc: 1-800-477-7766
 TouchTronics, Inc. 1-800-294-2570 or 1-574-294-2570

Web Site

Www.galls.com
 www.touchtronics.com

E-Mail

touchtronics@touchtronics.com or
 techsupport@touchtronics.com or
 'Contact Request' link on the web page

Component Parts List

1) 1 pc **M609** Switch Panel, 9 function





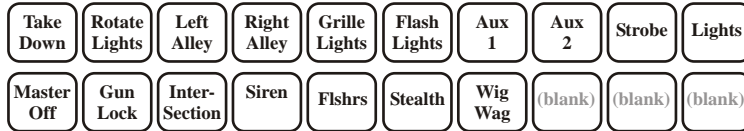



2) 1 set **C606.G1** XL 400 Switch Legends











3) 1 pc **C606.J1** Mounting Bracket



4) 1 kit **S606.F1** Fastener kit (panel & bracket)

- 2pcs BLT.5000 Hex Head Bolt 1/4-28 3/4" 
- 2pcs NTS.6005 Nylock Nut 1/4-28 
- 6pcs SCW.7000 Hex Head Screw 8 x 1/2" 
- 2pcs SCW.7001 Hex Head Screw 10 x 3/4" 
- 1pcs TRM.8001 Terminal #10 ring 3/16" 
- 1pcs WSH.9000 Washer, Ext Tooth #10 3/16" 

5) 1 kit **C609.H1** XL 400 Panel and Relay Harness Kit

- 1pc J1 Harness, 4 position Logic Power 
- 1pc J6 Harness, 4 position Pursuit Logic(on relay pack) 
- 1pc J3 Harness, 2 position Switch Output 
- 1pc J4 Harness, 3 position Switch Output 
- 1pc SL1 Wire, single, pink 
- 1pc SL2 Wire, single, tan 
- 1pc SL3 Wire, single, orange 
- 1pc SL4 Wire, single, yellow 

6) 1 kit **C609.H1R** Harness, Relay kit

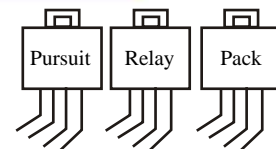

7) 3 pcs **RLY.Q30A12V.C** Relays, 30 Amp, automotive style



8) 1pc **TIE.T50MR** Cable tie, 7.5" - w/mount hole

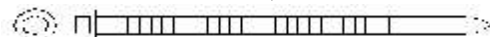

Operation: Light Bar Control Panel



Push Button Switches

- 1 Press switch button to toggle between ON and OFF
- 2 Switch changes color to indicate status: Red = OFF
Green = ON
- 3 All legends are back lit when power (+12v) is supplied to panel.

Pursuit Slide Switch

From the OFF Position, move knob to the right to select Pursuit ONE, TWO or THREE.

OFF - Pursuit Stand By - Position 0

OFF - Slide switch is far left.

Status Indicators - None or OFF

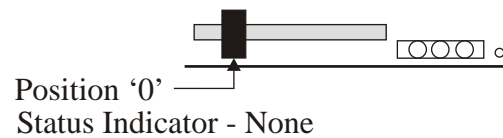

ON - Pursuit One - Position 1

Move slide switch right to position-1.

Status Indicator is Green.

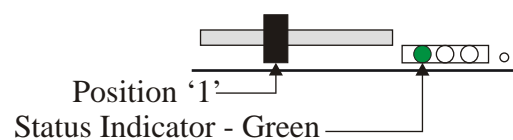

ON - Pursuit Two - Position 2

Move slide switch right to position-2.

Status Indicator is Yellow.

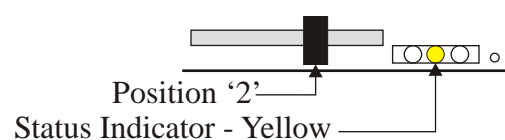

ON - Pursuit Three - Position 3

Move slide switch right to position-3.

Status Indicator is Red.

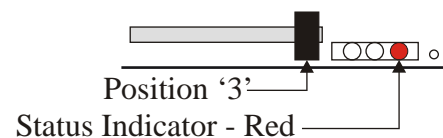

Planning: Light Bar Switch Programming

WARNING!

Use **ONLY** a volt meter to check voltage during installation and testing



Plan Your Installation

To maximize this panels special capabilities, plan ahead. Determine the switch functions, lights and/or special applications that will be used. Carefully read the push-button and pursuit switch program options before starting your installation.

Default Factory Push-Button Switch Settings

All push-button switches are factory set at 'Latching / Toggle' Push On - Push Off See below for programming options.

Use the factory default switch setting (latching) to operate most light bar functions such as: rotator lights, alley lights, take-down lights, etc. However, Gun-Locks typically require a momentary or a timed momentary switch. The factory default switch can be programmed as a momentary or timed momentary output.

Select Factory Default or a Program Option

Note: All switches are pre-set as latching (factory default, push on - push off) Program options are listed per each switch.

Push-Button Switch Program Options

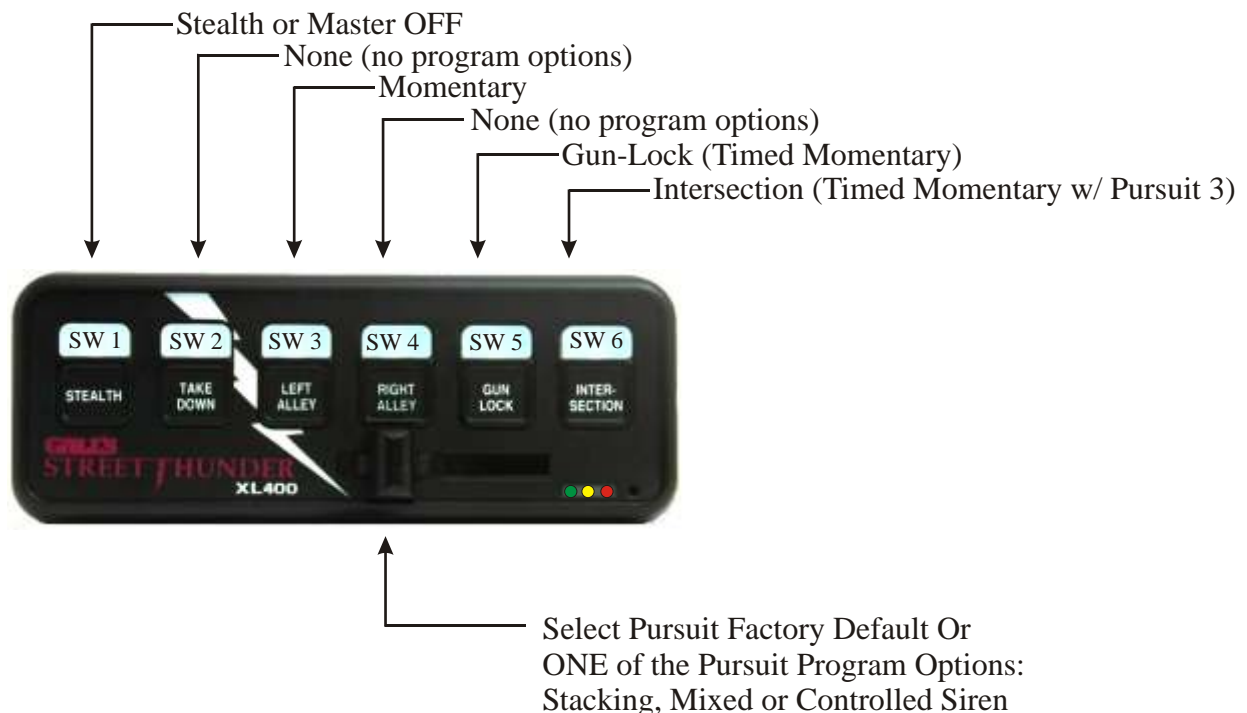

Programming Details: Push-Button Switches

Program Push-Button Switches

- 1) Locate the small hole in lower right-hand corner of panel front. Inside the small hole is the "Program Switch".
 - 2) *Gently* insert the end of a paper clip or similar device into the small hole, press and hold the Program Switch. Switch LEDs flash Off and then turn red or color of current program selected.
 - 3) When in program mode, no switch outputs will operate.
 - 4) According to your plan, identify the switches you want to program. Press the switch you are programming one, two or three times to select the program. The switch will turn green, yellow or red (factory default is red) to indicate the program selected. To store the selected program, leave the switch in the program color and exit program mode.
 - 5) To exit program mode, *gently* insert the paper clip into the small hole, press and hold the Program Switch again until the switch LEDs flash off and then cycle and flash several times and finally turn red and switch outputs will operate.
 - 6) Retest all switches to verify acceptance of program. If switch program is incorrect, reprogram switch a second time and retest program status.
- If problems persist call the factory at 1-800-294-2570.

Push Button Switch Programming Options

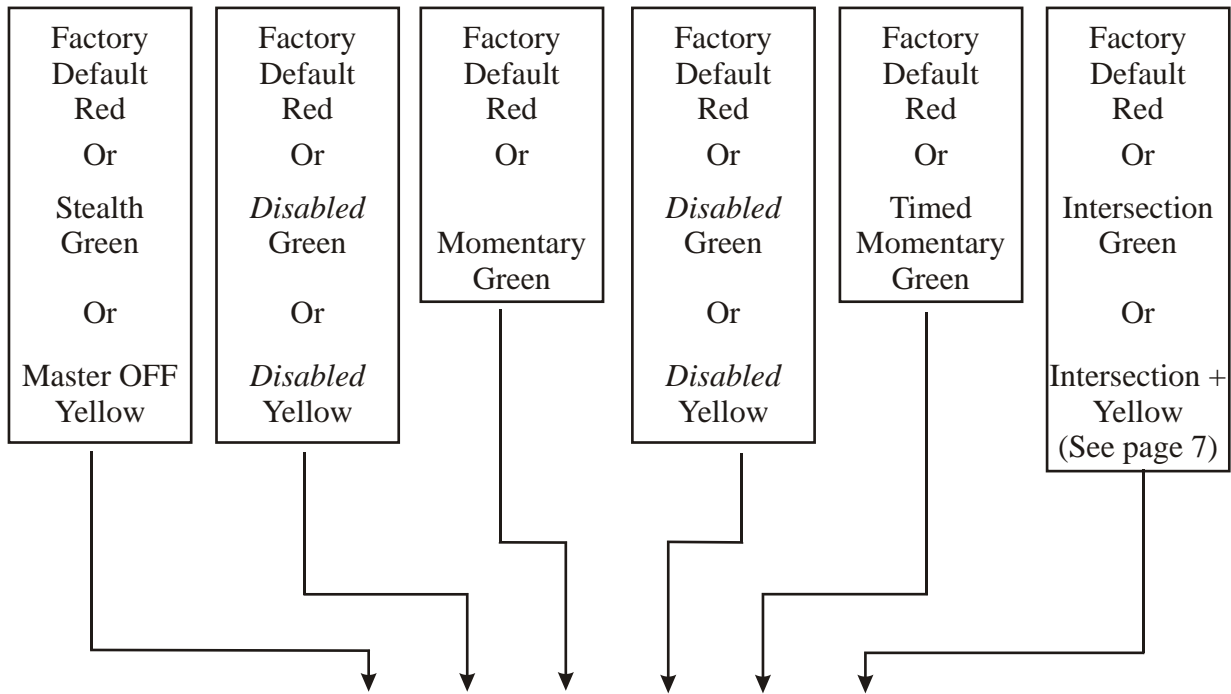

***NOTE:**
Only one (1) program option may be selected per switch!



Program Switch is located inside the small hole.

Programming Details: Push-Button Switches

Switch 1

 **Factory Default (Program Red)**

On/Off - Latching

Or  **Stealth Switch (Program Green)**

Press switch #1 - All push-button switches turn OFF - 'Go Dark'; Switch #1 flashes green to indicate stealth is ON and all other push-button switch back lights are Off (not green or red). If any pursuit switch is ON, stealth switch is denied. The pursuit switch must always be OFF before pressing stealth switch.

Or  **Master OFF (Program Yellow)**

Press switch #1 - All switches including pursuit switch will turn Off sequentially. The Master Off is released and returned to normal operation when any push-button switch is pressed. Note: All pursuit switches are denied until panel is returned to normal operation.

Switch 2

 **Factory Default (Program Red)**

On/Off - Latching

Option Disabled (Program Green)

Option Disabled (Program Yellow)

Switch 3

 **Factory Default (Program Red)**

On/Off - Latching

Or  **Momentary (Program Green)**

Momentary On - Press and hold switch. Output stays On as long as switch is held.

Switch 4

 **Factory Default (Program Red)**

On/Off - Latching

Option Disabled (Program Green)

Option Disabled (Program Yellow)

Switch 5

 **Factory Default (Program Red)**

On / Off - Latching

Or  **Gun Lock (Program Green) Timed Momentary**

Timed momentary On - Press and release switch to activate the timed momentary output. It can be programmed to operate a timed output from one (1) second to sixty (60) seconds.

To program timer: Place panel in program mode. Press and hold switch for the desired time that switch will be ON in normal operation. For example: If you press and hold the switch for fifteen (15) seconds in program mode, it will stay on for fifteen (15) seconds in normal operation.

Switch 6

 **Factory Default (Program Red)**

On / Off - Latching

Or  **Intersection (Program Green) Timed momentary on Switch 6**

Timed momentary On - Press switch to activate the timed momentary output. It can be programmed to operate a timed output from one (1) second to sixty (60) seconds.

Or  **Intersection+ (Program Yellow) Timed momentary and Pursuit Three and Siren:**

Timed momentary On - Press switch to activate the timed momentary output. It can be programmed to operate a timed output from one (1) second to sixty (60) seconds. When the Intersection switch is ON in normal operation, any lights connected to pursuit three program option will turn On. If pursuit three is the factory default, then only relay #3 will turn ON. If any of the other pursuit Three program options are selected, ALL three pursuit relays will turn ON. Siren is turned On by tapping switch #6 a second time during the timed output.

To program timer: Place panel in program mode. Press and hold switch for the desired time that switch will be ON in normal operation. For example: If you press and hold the switch for fifteen (15) seconds in program mode, it will stay on for fifteen (15) seconds in normal operation.

Installation: Bracket and Panel

Mount Bracket To Panel

- 1) Select 4pcs of the #8-1/2" hex head screws (SCW.7001) from the fastener kit (C606.F1).
- 2) Position mounting bracket (C606.J1) over the mounting holes in the panel (M609).
- 3) Using screw driver, screw the bracket to the panel.

Mount Bracket and Panel to Console or Stack Unit

- 1) Select 2pcs of the 1/4-28 3/4" hex head bolts (BLT.5000) and 2pcs of the 1/4-28 nylock nuts (NTS.6005) from the fastener kit (C606.F1).
- 2) Position the panel bracket sides between rack on stack unit.
- 3) Insert a hex head bolt through rack slot and through bracket slot on each side.
- 4) Place nylock nuts on the hex head bolts and screw until finger tight.
- 5) Rotate the panel front for optimum positioning.
- 6) Tighten the nylock nuts to secure panel in proper position.

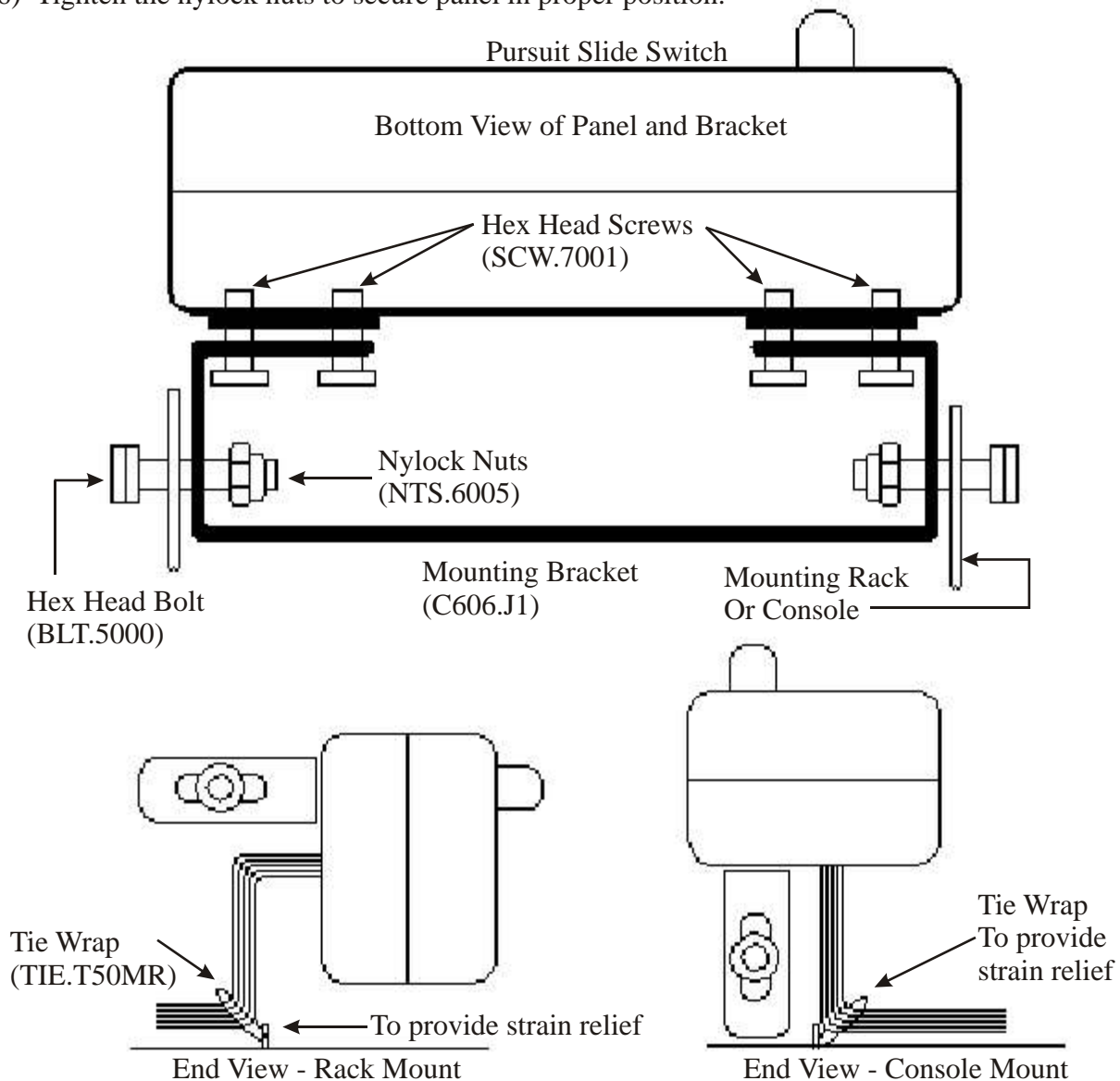

Electrical Installation: J1 Logic Power

Connector J1 - Logic Power Input

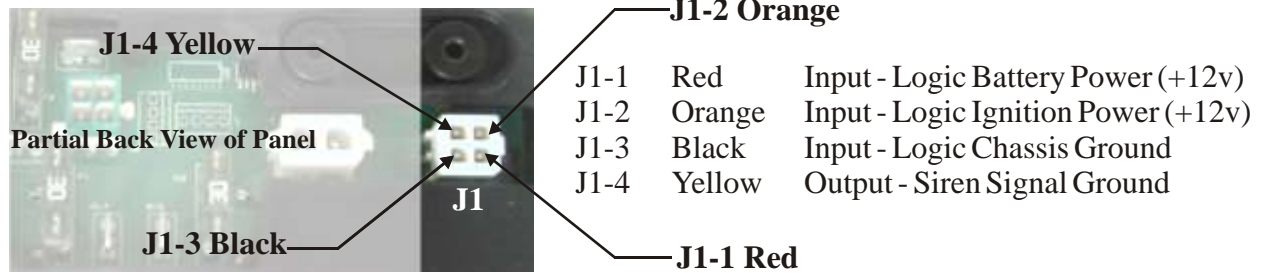

- 1) Connect the J1-1, Red wire to a constant +12v battery power source.
Note: For best performance, run a clean +12v (100mA) directly from the battery or a fuse that is NOT supplying any power to the light bar or any other type of high current device.
- 2) Connect the J1-2, Orange wire to +12v Ignition Power:
Install the Ignition Logic input (100mA) by running a wire to an ignition fuse or circuit that is only HOT when the ignition switch is ON and in the RUN position.
- 3) Connect the J1-3, Black wire to Chassis Ground:
 - A) Scrape all paint and grease away from the body frame.
 - B) Clean the area using an alcohol based cleaner to remove paint chips and grease.
 - C) Crimp the supplied #10, 3/16" ring terminal (TRM.8001) onto the J1-3 black ground wire.
 - D) Insert the ring terminal and the supplied #10, 3/16" star washer (WSH.9000) over the supplied 10x3/4" hex head, self-tapping ground screw (SCW.7001).
 - E) Tighten ground screw securely into clean frame area.
 - F) **A loose chassis ground connection WILL cause intermittent operation!**
- 4) If a siren will be used during panel operation, connect J1-4 yellow wire to any siren input which requires a ground. This will turn ON a siren tone when a ground is present.

WARNING!

Reversing the J1 Power Connector and the J6 Pursuit Relay Pack Connector on the panel *WILL* damage the panel.

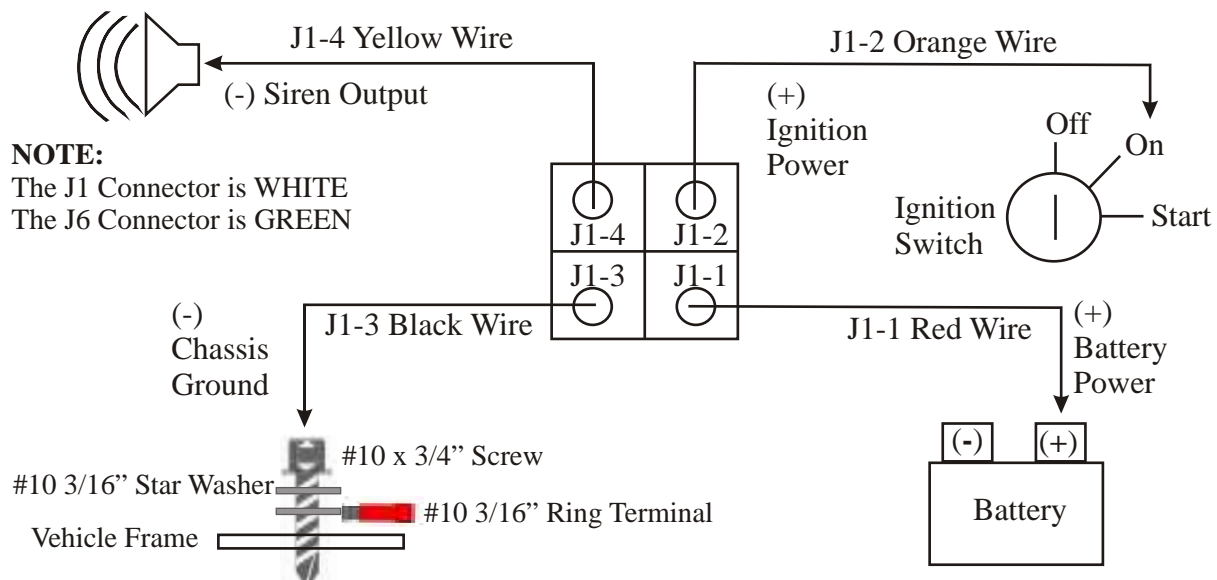

Scrape paint and clean area before installing ground screw.

A loose chassis ground connection WILL cause intermittent operation!

Testing: Logic Power Circuit

***ONLY Use a Volt Meter to Check Voltage on J1**



- 1) Set the volt meter to Volt Scale
 - A) Attach black lead from the volt meter to chassis ground.
 - B) With the J1 connector NOT plugged into the panel, use the red meter lead to probe wire and Verify meter readings with the chart below.

Pin#	Wire Color	Correct Voltage Reading - Ignition Switch OFF	Correct Voltage Reading - Ignition Switch ON
J1-1	Red Wire	+12v to 13.8v at ALL times	+12v to 13.8v at ALL times
J1-2	Orange Wire	0.0v to 1v	+12v to 13.8v ONLY - In Run Position
J1-3	Black Wire	0.0v to 0.5v at ALL times	0.0v to 0.5v at ALL times
J1-4	Yellow Wire	Do Not Test At This Time	Do Not Test At This Time

- 2) Ignition switch should be Off.
 - A) Plug J1 connector into panel.
 - B) Observe all switch and legend backlighting. All should be OFF.
- 3) Turn Ignition switch ON. Observe switch and lens backlighting.
 - A) Each switch will flash and cycle several times then turn solid red.
 - B) All back light LEDs will flash and cycle several times then turn solid red.
- 4) Press each switch in succession.
 - A) 1st press (ON), switch turns green and relay will click.
 - B) 2nd press (OFF) switch turns red and relay will click.
- 5) If something fails, does not light or does not click correctly, review the instructions and check all connections for proper, solid crimps. If all connections appear to be ok, call for technical assistance. Galls Inc. technical assistance number is: 1-800-477-7766

Electrical Installation: High Current Power

Battery Power Source

- 1) Run three (3) 12 gauge wires (not supplied) from the battery to Light Bar Control Panel.
- 2) Install a 30 Amp Auto-Reset circuit breaker or a 30 Amp In-Line fuse (not supplied) onto each wire within at least 18" of the battery.

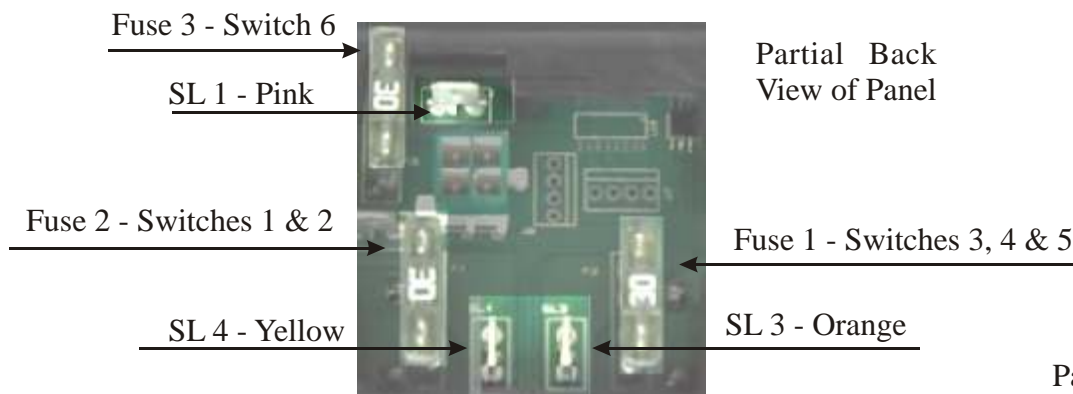
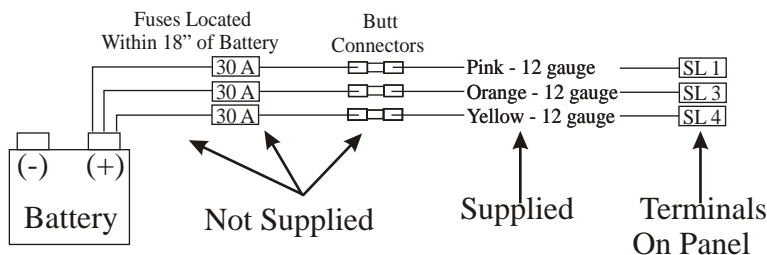

Electrical Installation: Switch Outputs

Before installing outputs test voltage
***ONLY Use a Volt Meter to Check Voltage**
on switch inputs and outputs

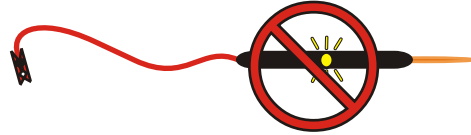

Pre-Testing the 30 Amp Inputs / Switch Outputs

- 1) Set the volt meter to Volt Scale
 - A) Attach black lead from the volt meter to chassis ground.
 - B) Use the red meter lead to probe wire and verify meter readings with the chart below.

Sws #	Pin #	Wire Color	30 Amp Input Voltage (At all times)	Switch Off	Switch On
	SL 1	Pink Wire	+12v to 13.8v		
	SL 3	Orange Wire	+12v to 13.8v		
	SL 4	Yellow Wire	+12v to 13.8v		
1	J3-1	Blue Wire		0.0v to 1.0v	12.0v to 13.8v
2	J3-2	Green Wire		0.0v to 1.0v	12.0v to 13.8v
3	J4-1	Violet Wire		0.0v to 1.0v	12.0v to 13.8v
4	J4-2	Gray Wire		0.0v to 1.0v	12.0v to 13.8v
5	J4-3	Brown Wire		0.0v to 1.0v	12.0v to 13.8v
6	SL 2	Tan Wire		0.0v to 1.0v	12.0v to- 13.8v

- 2) If a failure occurs or an improper voltage is found, review the instructions and check to ensure all connections are proper and solidly crimped. If all connections appear to be ok, call for technical assistance. Galls Inc. technical assistance number is: 1-800-477-7766

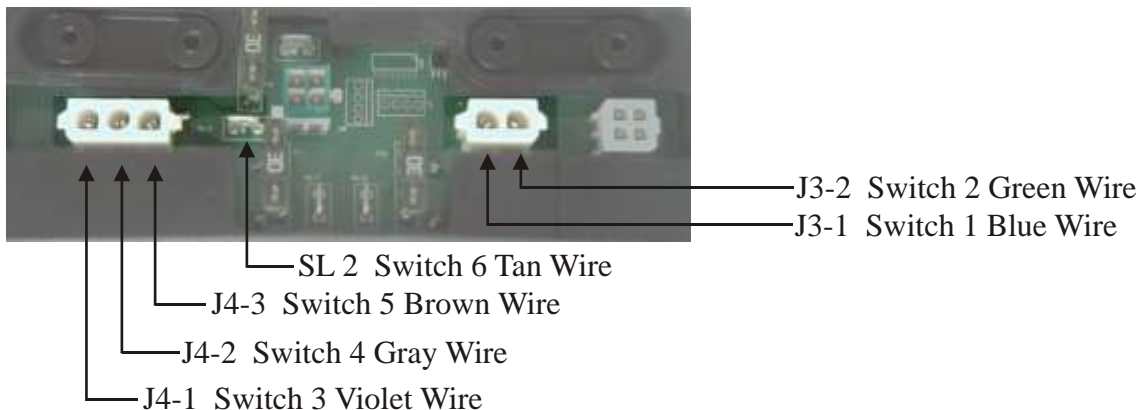

Switch Output Installation

- 1) Determine if any push-button switches will be programmed.
 Note: If Stealth or Master Off are programmed, do not install a function or light on switch 1.
- 2) Connect the lights or gun-lock to the wires in connector J3, J4 and SL 2 (tan wire).
- 3) Program push-button switches if required. See pages 6 and 7 for details and instructions.
- 4) Test outputs
 - A) One at a time, turn all push-button switch outputs On.
 - B) The proper light should turn ON. If it is a momentary or timed momentary - verify that switch is only on for selected time.
 - C) If any light does not turn on properly - check all connections and voltages (See table above) before calling for technical assistance.

Planning: Pursuit Slide Switch Program Details

The Pursuit Slide Switch is designed to reduce installation time and to improve flexibility in the usage of the lights used during the operation of Pursuit ONE, TWO, or THREE

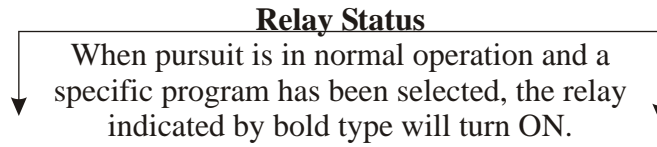
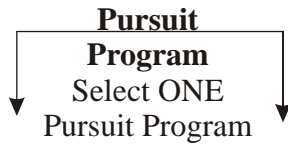

Pursuit Factory Default
Status Indicator - None

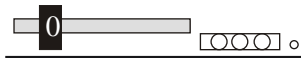

Sw Position 0	Sw Position 1	Sw Position 2	Sw Position 3
Relay 1 OFF	Relay 1 ON	Relay 1 OFF	Relay 1 OFF
Relay 2 OFF	Relay 2 OFF	Relay 2 ON	Relay 2 OFF
Relay 3 OFF	Relay 3 OFF	Relay 3 OFF	Relay 3 ON
NO Siren	NO Siren	NO Siren	NO Siren

Stacking Program

Status Indicator - Green



Sw Position 0	Sw Position 1	Sw Position 2	Sw Position 3
Relay 1 OFF	Relay 1 ON	Relay 1 ON	Relay 1 ON
Relay 2 OFF	Relay 2 OFF	Relay 2 ON	Relay 2 ON
Relay 3 OFF	Relay 3 OFF	Relay 3 OFF	Relay 3 ON
NO Siren	NO Siren	NO Siren	Siren ON option

Mixed Program

Status Indicator - Yellow



Sw Position 0	Sw Position 1	Sw Position 2	Sw Position 3
Relay 1 OFF	Relay 1 ON	Relay 1 OFF	Relay 1 ON
Relay 2 OFF	Relay 2 OFF	Relay 2 ON	Relay 2 ON
Relay 3 OFF	Relay 3 OFF	Relay 3 OFF	Relay 3 ON
NO Siren	NO Siren	NO Siren	Siren ON option

Controlled Siren Program

Status Indicator - Red



Sw Position 0	Sw Position 1	Sw Position 2	Sw Position 3
Relay 1 OFF	Relay 1 ON	Relay 1 ON	Relay 1 ON
Relay 2 OFF	Relay 2 OFF	Relay 2 ON	Relay 2 ON
Relay 3 OFF	Relay 3 OFF	Relay 3 ON	Relay 3 ON
NO Siren	NO Siren	NO Siren	Siren ON option

Sample - Pursuit Relay Installation

Example of Pursuit installation showing how the different pursuit programs would affect a specific set of lights.

Sample - Factory Default Pursuit Program

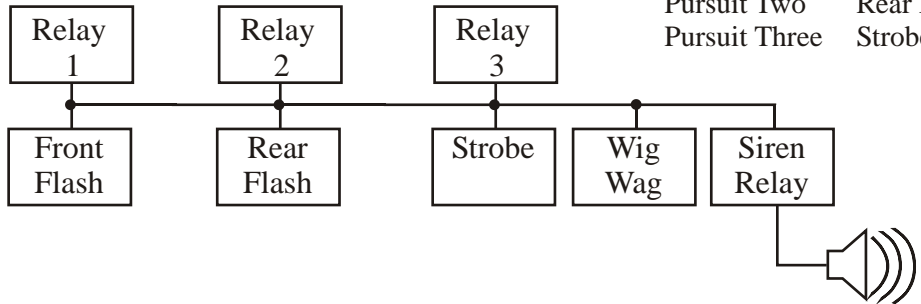

Pursuit One Only Front Flashers, ON
 Pursuit Two Rear Flashers, ON
 Pursuit Three Strobe, Wig Wags & Siren, ON

Sample - Stacking Pursuit Program

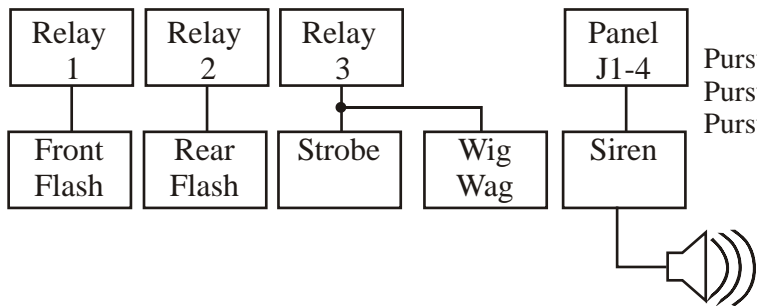

Pursuit One Only Front Flashers, ON
 Pursuit Two Front & Rear Flashers, ON
 Pursuit Three Front & Rear Flashers, Strobe, Wig Wags & Siren, ON

Sample - Mixed Pursuit Program

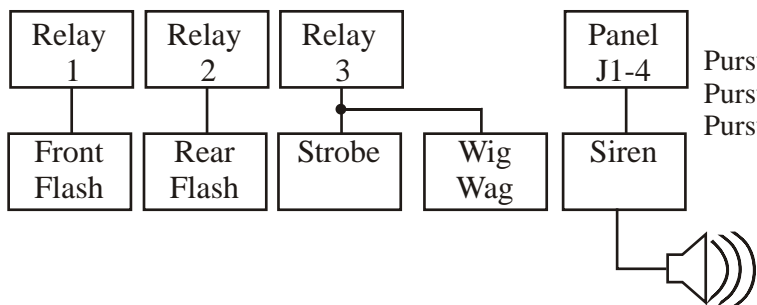

Pursuit One Only Front Flashers, ON
 Pursuit Two Only Rear Flashers, ON
 Pursuit Three Front & Rear Flashers, Strobe, Wig Wags & Siren, ON

Sample - Controlled Siren Pursuit Program

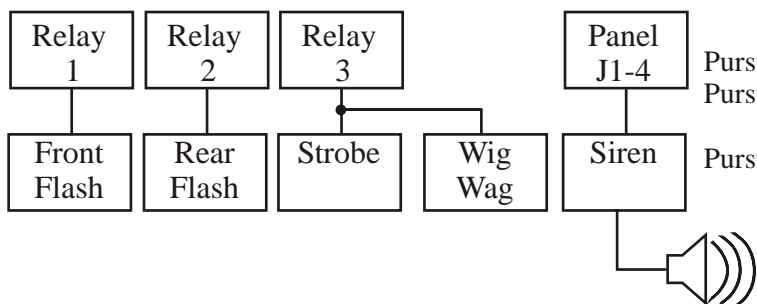

Pursuit One Only Front Flashers, ON
 Pursuit Two Front & Rear Flashers, Strobe & Wig Wags, ON
 Pursuit Three Front & Rear Flashers, Strobe, Wig Wags & Siren, ON

Programming: Pursuit Slide Switch Program Details

PROGRAMMING PURSUIT SLIDE SWITCH

- 1) Locate small hole in lower right corner of panel front (see photo on page 6).
- 2) To put panel into program mode, insert the end of a paper clip into the small hole.
- 3) Press and hold the Program Switch with the paper clip.
- 4) All push-button switches flash OFF, then turn red and will not operate any output, which indicates panel is in the 'program mode'.
- 5) Leave pursuit slide switch in position 0 or move to right to select pursuit program option.

Program	Switch Position	LED Color
Factory Default	Position 0	Off
Stacking	Position 1	Green
Mixed	Position 2	Yellow
Controlled Siren	Position 3	Red

- 6) To store program, leave pursuit slide switch in selected position.
- 7) Exit 'program mode' by pressing 'program switch' with paper clip end. All switch LED's and Pursuit status box LED's will cycle and flash.
- 8) NOTE: Any light or siren connected to pursuit relays will turn ON as program is exited.

Electrical Installation: Pursuit Relays

- 1) Select the pursuit program that will be installed in your vehicle. Factory Default, Stacking, Mixed or Controlled Siren. See page 14 for sample installation.
- 2) Determine which light will be operated by each relay.
- 3) Connect lights to selected relays 1, 2 or 3.
- 4) Connect siren output, yellow wire (J1-4) to any negative siren input. Verify that the input selected is logic ground input (100mA). Note: If an incorrect siren input is selected, the panel output will be damaged.
- 5) Mount relays under dash or inside console.
- 6) Plug J4 into back of panel near fuses.

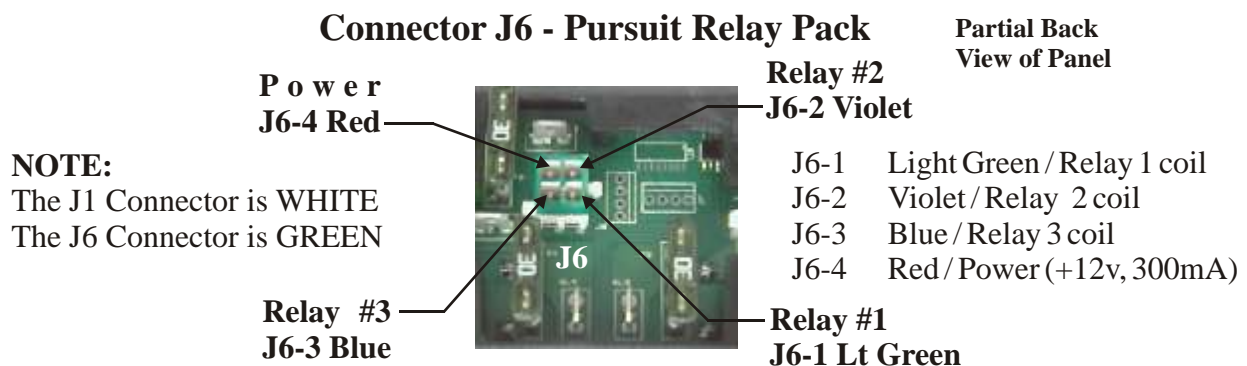

WARNING!

Reversing the J1 Power Connector and the J6 Pursuit Relay Pack Connector on the panel *WILL* damage the panel.

Electrical Installation: Pursuit Relays

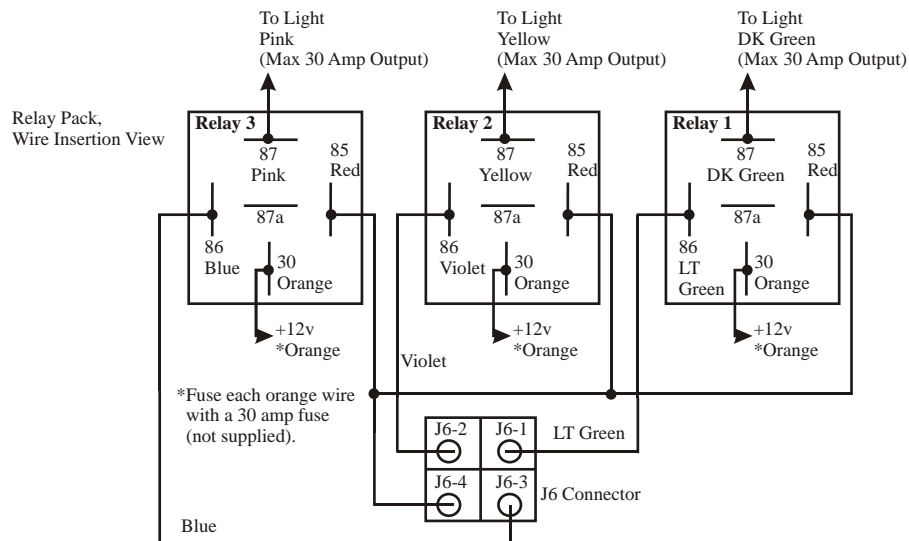

Testing: Pursuit Relays

- 1) Test each pursuit output in factory default mode.
- 2) Turn on each switch position one at a time and verify that the proper lights turn ON.
- 3) Program the pursuit switch if any option has been selected.
- 4) Turn on each switch position again one at a time and verify that proper lights turn ON.
- 5) Turn OFF all push-button switches and pursuit switch.

Testing: Final Checkout

- 1) Check all light outputs.
 - A) Turn ignition On.
 - B) During flashing sequence, press and hold Switch 1.
 - C) Panel will turn on walk-around-test
 - D) Each switch will turn On (in succession) for 4-seconds, including the pursuit switch.
 - E) All outputs will turn off for 8-seconds and switch button and pursuit LED's will display the selected program option color. This test is repeated until Switch 1 is pressed a second time. Note: During walk-around-test, the special timing and combination lights will not operate, but will only display output attached to relay.
- 2) Check Ignition Master OFF
 - A) Turn ON all switches including the pursuit slide switch.
 - B) Turn OFF the ignition switch.
 - C) All switches and lights should turn OFF at 1/4 second intervals.
- 3) Remove each fuse one at a time and check to see which switches turn yellow. The blown fuse is indicated by specific switches turning yellow.

Fuse 1 Removed	Switches 3, 4 and 5 turn Yellow
Fuse 2 Removed	Switches 1 and 2 turn Yellow
Fuse 3 Removed	Switch 6 turns Yellow

Trouble Shooting Guide

Use a digital or analog voltmeter to check power and voltage!

Symptom	Possible Cause	Remedy
<p>1.0 Switches and lenses are not backlit and relays do not click when switch is pressed.</p>	<p>1.1 No power/(+12v) or ground on power connector, J1.</p> <p>1.2 Power connector, J1 is not plugged into panel connector correctly.</p> <p>1.3 Microprocessor, which controls panel, is not active.</p> <p>1.4 Wire harness pinned incorrectly.</p>	<p>1.1a Check +12 voltage on Red wire (J1-1). Should be +12v at all times.</p> <p>1.1b Check +12 voltage on Orange wire (J1-2). Should be +12v when ign is ON.</p> <p>1.1c Check ground on black wire(J1-3).</p> <p>1.1d Correct improperly crimped terminals.</p> <p>1.2 Remove connector and reinstall. Push the connector securely onto header.</p> <p>1.3 Return panel to factory for replacement</p> <p>1.4 Check pin-out on wire harness. If defective, call factory for replacement.</p>
<p>2.0 Panel will not maintain program</p>	<p>2.1 Power (+12v) lost battery wire.</p> <p>2.2 Battery (Red) wire (J1-1) is not pinned correctly in the connector.</p>	<p>2.1a Check power (+12v) on red (J1-1) wire. Power (+12v) should be present at all times, when ignition switch is ON or OFF.</p> <p>2.1b Correct improperly crimped terminals.</p> <p>2.2 Check pin-out of J1 connector. Call factory for replacement connector if defective.</p>
<p>3.0 Fuse blows or light will not turn on completely.</p>	<p>3.1 Maximum current load has been exceeded.</p> <p>3.2 Wire size/gauge is too small for current load and length of wire.</p>	<p>3.1 Check current requirement of lights operated in circuit. If too high separate lights or add extra relay with fuse.</p> <p>3.2 Increase wire size/gauge between panel and function or power source (battery).</p>

Trouble Shooting Guide

Symptom	Possible Cause	Remedy
<p>4.0 Relays click, but the function/light does not turn ON.</p>	<p>4.1 No power (+12v) on one or all of the high current power input wires.</p> <p>4.2 Panel or master fuses blown.</p> <p>4.3 Power output tan (SL 2) wire for #6 switch is installed incorrectly.</p> <p>4.4 Improper ground on function, such as a light bar.</p> <p>4.5 Improper terminal crimp on wire harness.</p> <p>4.6 Function or light bar is defective.</p>	<p>4.1 Check power (+12v) on the pink (SL 1) wire, orange (SL 3) wire, and red (SL 4) wire. Locate where voltage is lost in harness and correct.</p> <p>4.2a* Panel Fuses - Check voltage on both sides of each fuse. Replace if needed.</p> <p>4.2b* Master Fuse - Check master fuse or circuit breaker, usually located within 18" of vehicle battery. Replace if needed.</p> <p>4.3 Check installation of tan wire. It should be installed on SL 2, next to J4 header (3 way connector).</p> <p>4.4a Use volt meter to verify +12v on output terminal and on function that is not operating.</p> <p>4.4b If +12v is present, check and correct any improper ground connections.</p> <p>4.5a Use volt meter to verify +12v on output terminal and on function that is not operating.</p> <p>4.5b Check voltage at all terminal crimps and connectors. Re-crimp or replace terminals if needed.</p> <p>4.6 If +12v is present, function light bar may be defective. Test function or light bar and replace if necessary.</p>

*Fuses are located on back of panel. Fuse #1 protects switch outputs 3, 4 and 5. Fuse #2 protects switch outputs 1 and 2. Fuse #3 protects switch output 6.

Special Applications

1) Controlling a single function with the Pursuit Switch and a Push Button Switch

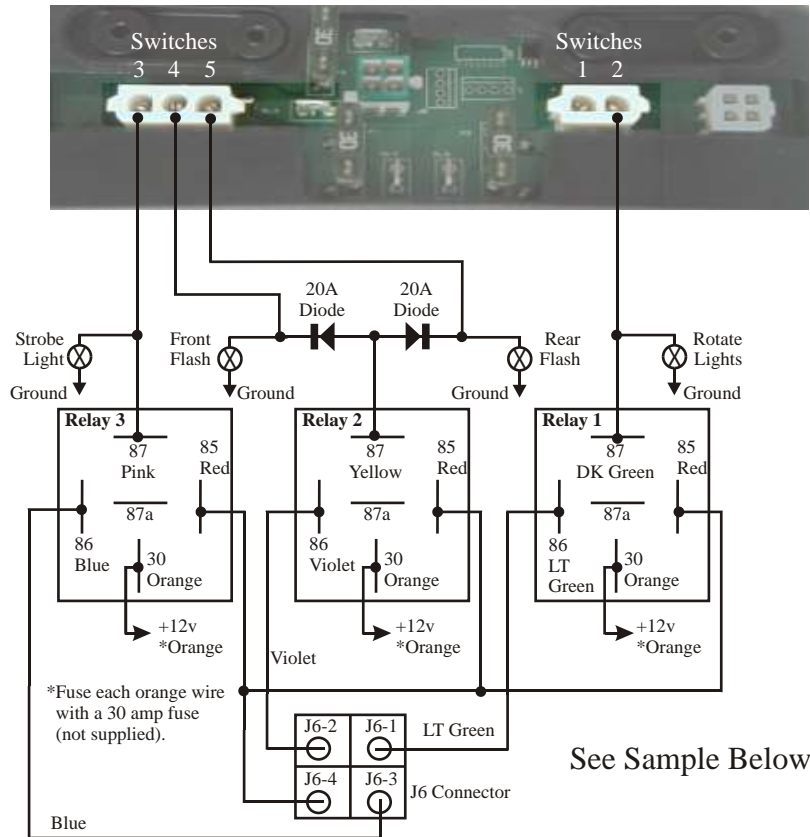

2) Adding High Current To Switch Panel Output

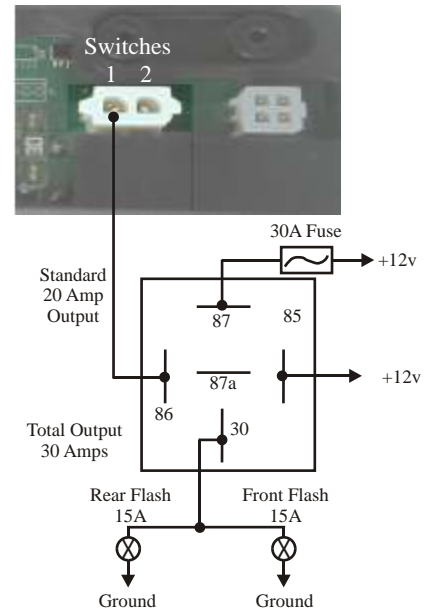

1a) Sample - Pursuit Relay / Stacking Combination

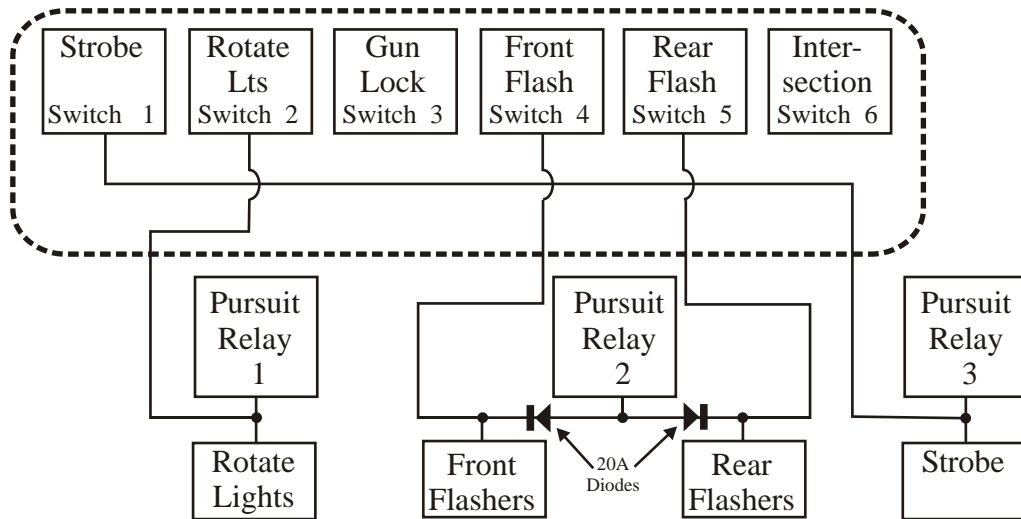

- | | | |
|---------------|----|---|
| Pursuit One | ON | Only Rotate Lights |
| Pursuit Two | ON | Front & Rear Flashers, Rotate Lights |
| Pursuit Three | ON | Front & Rear Flashers, Rotate Lights & Strobe |

TouchTronics, Inc. Warranty Policies and Procedures

The following revised warranty procedures will be implemented and effective March 1, 2002.

- 1) All products will now be shipped with an individual bar code attached.
- 2) The bar code will include some or all of the following information.
 - A) Date of Manufacture
 - B) Serial Number
 - C) Private Code
 - D) Part Number
- 3) Warranty Cards are no longer required to be eligible to receive technical support and service.
- 4) Each individual product is warranted under the TouchTronics Limited Warranty program for 1 full year from date of purchase or a *maximum* of 2 years from the date of manufacture.
- 5) No product will be covered under the TouchTronics Limited Warranty program that has a manufacture date older than 2 years.
- 6) To receive technical support or warranty service, simply call our technical support center during regular business hours.
- 7) To enable our technical support staff to better serve you, please have the following information available when you call.

Date Of:	
Manufacture	
Purchase	
Installation	

Vehicle Information:	
Dealer Name	
Dealer Phone	
Make / Model	

Product Information:	
Part Number	
Serial Number	
Private Code	

Please fill in all pertinent information at the time of purchase or installation

Limited One (1) Year Warranty

Section One

Seller will warranty any product originally manufactured and sold by seller for a period of 12 months (1 year) from the original retail sale or in-service date. It is the purchaser's responsibility to complete the warranty registration card and mail it to seller within thirty (30) days of the retail sale date. Seller will not warrant any product that does not have a warranty card on file with the seller's warranty department. Warranty card must be received within one year of the date of manufacture.

Section Two

The following are in lieu of all warranties, express, implied or statutory including but not limited to, any implied warranty of merchantability of fitness for a particular purpose and of any other warranty obligation on the part of seller. Sellers, except as otherwise hereinafter provided, warrant the goods against faulty workmanship or the use of defective materials for a period of one year.

Seller's sole and exclusive liability shall be (at seller's option) to repair, replace or credit buyer for and such goods which are returned by buyer during the applicable warranty period set forth above, provided that (I) seller is promptly notified in writing or phone upon discovery by buyer that such goods failed to conform and an explanation of any alleged deficiencies, (II) such goods are returned to seller, (III) seller's examination of such goods shall disclose that such alleged deficiencies actually exist and were not caused by accident, misuse, neglect, alteration, improper installation, unauthorized repair or improper testing. If seller elects to repair or replace such goods, seller shall have a reasonable time to make such repairs or replace such goods.

Seller's warranties as herein above set forth shall not be enlarged, diminished, or affected by, and no obligation or liability shall arise or grow out of, seller's rendering of technical advice or service.

Products damaged by the customer or during installation can not be claimed as a warranty. All devices returned that are not covered under the seller's warranty policy, will be charged a minimum of \$25.00 for evaluation plus additional charges for components and labor to repair the device not to exceed the original selling price. Seller considers the following to be typical examples of customer or installation damage: burned or broken traces on the printed circuit board, burned or damaged components, dirt or water residue on the printed circuit board or inside the case, modifications by the customer, broken cases or housings and dead batteries.

Section Three

A return material authorization number (RMA) must be issued by seller before any product is returned for evaluation or repair. Warranty repairs must be completed at authorized repair facilities.

This Page May Be Used For Installation Notes Or Diagrams: