

American Aluminum Accessories

R. E. S. C. U. E. Remote Control Systems



914 PowerTouch Remote Control Receiver With
One Key Chain Transmitter & One Oval Transmitter

**Please read entire instruction manual *prior* to starting the
R.E.S.C.U.E. Remote Control System Installation.**

Special Features and Applications

Easy to Open

Unlatch and open door - at the touch of a button.

Power

Each output is 5 Amp, switched relays.

Range

Typical antenna range is 100 to 300 feet.

Contents, Installation Tools, Technical Support

Contents

Special Features and Applications	Page 1
Contents, Installation Tools, Technical Support	Page 2
Specifications	Page 3
Component Parts List	Page 4
Operation: R.E.S.C.U.E. Remote Control	Page 5
Installation: Planning	Page 6, 7
Installation: Electrical - Receiver Power & Ground	Page 8
Installation: Setup 1 and Setup 2	Page 9
Installation: Electrical - Door Unlock / Lock Circuit	Page 10, 11
Installation: Safety Disable Switch	Page 11
Installation: Antenna & Range	Page 12
Installation: Final Test	Page 13
Trouble Shooting Guide	Page 14, 15, 16
Limited One (1) Year Warranty	Page 17
Blank Page: Notes, Drawings, etc.	Page 18

Installation Tools

Voltmeter, analog or digital	Hand Drill
Phillips Screw Driver	Assorted Drill Bits
Adjustable Wrench	Needle Nose Pliers
Screw Driver	Wire / Connector Crimping Tool
Diagonal Wire Cutter	Wire Stripper
To Clean Grounding Pad:	Scraper, Sand Paper, Alcohol Based Cleaner

Technical Support

Visit the factory website to download a copy of these instructions, e-mail technical questions and see other TouchTronics, Inc. products.

TouchTronics, Inc. Phone / Fax Numbers

Indiana Local	1-574-294-2570
Toll Free	1-800-294-2570
Fax	1-574-293-1611

TouchTronics, Inc. Web Site

www.touchtronics.com

TouchTronics, Inc. E-Mail

Customer Service	touchtronics@touchtronics.com
Technical Support	techsupport@touchtronics.com
Or	'Contact Request' link on the web page
<i>(Contact TouchTronics, Inc. For Electrical Installation Problems Only)</i>	

American Aluminum Phone / Fax Numbers

Customer Service / Toll Free	1-800-277-0869
Customer Service / Direct	1-850-584-3969
Fax	1-850-584-8485
<i>(Contact American Aluminum For Mechanical Installation Problems And Replacement Components.)</i>	

American Aluminum Web Site

www.ezrideronline.com











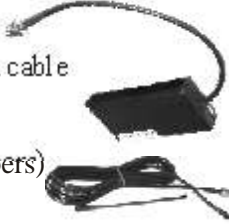



Specifications

914 Receiver:	FCC Approved
RF System	19,000 Codes
Voltage	12 Volt DC (available in 24 Volt DC)
Output	(4) 10 Amp Relays (+12v)
Frequency	300 MHz
Range	60 Feet (typical - using standard antenna)
Note:	Range may be extended with an externally mounted antenna
914 Transmitter (keychain):	FCC Approved
RF System	19,000 Codes
Battery	12 Volt DC (silver oxide #392)
Cycles	32,400 One Second Pulses
Frequency	303 MHz
914 Transmitter (oval):	19,000 Codes
Battery	9 Volt DC
Cycles	7,300 One Second Pulses
Frequency	303 MHz
Note:	Key chain style transmitters are water resistant, NOT water proof Oval style transmitters are water and dust resistant
Physical:	
Receiver:	4 ½" x 2 ½" x 1" (width, height, depth)
Transmitter:	1 ½" x 2" (width, length) key chain style 2" x 4 ½" (width, length) oval(hand held) style
Antenna:	
Flex Whip	9 " External, Bulkhead Mount
Cable	14' Shielded Coaxial Cable
Relay (external):	
Type	Form C, SPDT
Coil Current	100mA
Switching Current	30 Amp
Coil Voltage	12VDC
Toggle Switch:	
Type	SPST, On/Off Latching
Red Status Light	On
Current	30 Amp
Voltage	12VDC



Your R.E.S.C.U.E. Remote Control System comes with a Red Lighted Toggle Switch. When installed and used properly, this switch will deactivate the system while the vehicle is in motion. Additionally, DO NOT activate the 'Child Safety Switch' as this will prevent the door from opening when the transmitter button is pressed.

Component Parts List

- 1) **1 kit 9142MFW/1/1X 914 PowerTouch Remote Control System**
 - 1 pc 914R RF Receiver, 4 Channel w/flex whip antenna cable 
 - 1 pc ANT.FW914 Flex whip antenna (complete assembly) (See page 13 for individual component numbers)
 - 1 set C841.H1 Harness - 6 wire, 10' 
 - 1 pc 914T2 Transmitter, 2 button key chain style 
 - 1 pc 914T2X Transmitter, 2 button oval style 
- 2) **1 pc S840.B2 Belt Loop Holder, for oval style transmitter** 
- Optional **S840.B1 Belt loop holder, for keychain style transmitter**
- 3) **1 kit S841.M1 R.E.S.C.U.E. - Fastener / Switch Kit**
 - 1 pc SCW.7000 8" x 1/2" self drilling screw 
 - 5 pcs TRM.8014 16g blue, butt connector 
 - 1 pc TRM.8001 18g red, 3/16" ring terminal 
 - 1 pc WSH.9000 3/16" external tooth star washer 
 - 1 pc VEL.H008 1" x 3" black velcro - hook 
 - 1 pc VEL.L008 1" x 3" black velcro - loop 
 - 1 pc C814.L1 Do Not Engage Child Safety Switch Label (Place over safety lock on door used by k9) 
 - 1 pc SWS.TG18 On/Off, panel mount, red lighted toggle switch 
- 4) **2 pcs RLY.Q30A12V.C 30 Amp, 12vdc, spdt, automotive relay** 
- 5) **1 kit S841.M2 9 Volt Battery for Oval Transmitter**

Operation: R.E.S.C.U.E. Remote Control System

Transmitters:

- | | | |
|----|---------------------------------------|-------------------------------------------------------------------------------------------------------------|
| 1) | Press and release button
Or | Signal is sent to receiver - 1 second pulse |
| 2) | Press and hold button | Signal is sent to receiver as long as button is held. Signal will stop when button is released. |
| 3) | Red Status LED | A) LED On red indicates signal is being sent
B) LED On bright and solid indicates battery voltage is ok. |

Transmitter Operation

Receiver Operation

2 Button Transmitter	Channel	Function	Output	Power Output <small>All outputs must be same polarity</small>	Signal Type
1	1	Motor or Lamp	5 Amps Max	+12v or Ground(-)	Momentary
1 & 2 <small>Pressed at the same time</small>	2	Motor or Lamp	5 Amps Max	+12v or Ground(-)	Momentary
2	3	Motor or Lamp	5 Amps Max	+12v or Ground (-)	Momentary

Unlocking Rear Door

Press **Button 1** to unlock rear door. When the radio frequency (RF) signal is received by the receiver, the relay (supplied) energizes the factory electric door lock mechanism and then unlocks the door.

Opening Rear Door

Press **Button 2** to open the rear door. When the radio frequency (RF) signal is received by the receiver, the actuator (supplied) unlatches the rear door, the gas strut pushes the door to the fully extended position to allow the K9 to exit the vehicle.

Locking Rear Door

Press both buttons together to lock the rear door. The radio frequency (RF) signal is received by the receiver, the relay (supplied) energizes the factory electric door lock mechanism and then locks the door.

Interference Warning

All RF signals are subject to **INTERFERENCE** - including but NOT limited to: other RF antennas, other RF signals being broadcast at the same time, other RF devices (radios, radar devices), large pieces of metal or metal buildings, large bundles of wire (inside a vehicle), switching power supplies, and motors of any kind.

The RF signal can pass through obstacles in the line of sight such as; wood, glass or plastic. RF signals cannot pass through any type of metal or tinted windows which have been tinted with a metalized film. All factory tinting & some aftermarket tinting use the metalized film technology.

Installation: Planning

Test lights can cause vehicle computer damage if the wrong wires are probed and can cause the air bag systems to activate (deploy). Pay close attention to all caution labels in the vehicle. TouchTronics, Inc., will assume absolutely **NO** responsibility whatsoever for this, or any other damage done to the vehicle, or any personal injury due to improper installation. Refer to the limited warranty for details.

WARNING!
Use **ONLY** a volt meter to check voltage during installation and testing.
**Using a test light WILL damage the outputs!*



1) Choose the desired setup

Setup 1 - Door Unlatch and Door Open Only

2 Button Transmitter	Press	Signal Output	Description
Channel 1 - Unlock Dog Door or Unlock All Doors	Button 1	+12v / 5 Amp	Momentary
Channel 2 - N/A	N / A	N / A	N / A
Channel 3 - Door Unlatch and Open	Button 2	+12v / 5 Amp	Momentary

Setup 2 - Door Unlatch and Door Open With Door Lock and Door Unlock

2 Button Transmitter	Press	Signal Output	Description
Channel 1 - Unlock Dog Door or Unlock All Doors	Button 1	+12v / 5 Amp	Momentary
Channel 2 - Lock Dog Door or Lock All Doors	Buttons 1 & 2	+12v / 5 Amp	Momentary
Channel 3 - Door Unlatch and Open	Button 2	+12v / 5 Amp	Momentary

2) Receiver Output Voltages

- A) The receiver has four output voltages (channels) which will operate four separate circuits. The output voltage is 12 volts direct current (vdc). The maximum drive current for each of the four output channels is 5 amps (maximum). The four outputs can (drive) turn On small bulbs, relay coils or small motors.
- B) Check the power requirement for the bulb or motor before connecting to the receiver. The relay coil should be rated for the current requirements. The maximum allowable coil current is 5 amps @ 12vdc or 60 watts.

3) Select Receiver & Antenna Mounting Location

- A) Typically the receiver is mounted under the dash, as high up as possible and away from any bundled wires, other RF devices or switching power supplies. **DO NOT** mount behind any metal or tinted windows. **DO NOT** install the receiver unit under the hood of the vehicle or in the door as the receiver is **NOT** water proof. Water damage will **NOT** be covered under the warranty.
- B) The antenna is the long, black, coaxial cable on the opposite end of the receiver housing from the wire harness connector. The antenna should be mounted on the roof of the vehicle. The antenna should **NOT** touch any metal or window tinting, nor be mounted near any other RF devices, any bundled wires or other antennas. RF signals from base radios can overwhelm the RF signal from the transmitter to the receiver and cause a decrease in range and/or a slow response time.
- C) Select a chassis ground location that **DOES NOT HAVE ANY OTHER** grounds attached to it, as a ground loop or signal back feed can occur.
- D) **DO NOT mount the receiver and antenna:**
 - 1) Within 6 feet of a motor
 - 2) Near large bundles of wires
 - 3) Near other antennas or RF devices
 - 4) Switching power supplies
 - 5) The antenna should not be touching any metal as this grounds the RF (radio frequency) signal

Range of your Remote Control is affected by the installation location of the receiver antenna.

Installation: Planning, Continued

On/Off Toggle Switch

Select a place on the dash or console that is easily accessible and easily visible so that the status indicator light on the switch may be seen.

Factory Door Lock

Vehicle door lock circuits are factory designed as positive pulse, negative pulse or reversal rest @ ground circuits. Determine which type of door lock circuit is used in your vehicle.

Positive Pulse System: The switch has 3 wires. The input terminal, usually the center terminal, is +12v. When the switch knob is pressed (momentarily On) one of the other terminals is also +12v. This means that the switch is sending a +12v (positive pulse) signal to lock or unlock the door. There is a special relay in this circuit which handles the 'reversal rest @ ground' circuit required for most motor operations. Most GM vehicles use a Positive Pulse circuit for door locks. Check the number of wires on the switch and check the input wire to the switch. It should be a +12v signal. See diagram pg 11.

Negative Pulse System: The switch has 3 wires. The input terminal, usually the center terminal, is ground. When the switch knob is pressed (momentarily On) one of the other terminals is also ground. This means that the switch is sending a ground (negative pulse) signal to lock or unlock the door. There is a special relay in this circuit which handles the 'reversal rest @ ground' circuit required for most motor operations. Most foreign cars use a Negative Pulse circuit for the door locks. Check the number of wires on the switch and check the input wire to the switch. It should be a ground signal. See diagram pg 11.

Reversal Rest @ Ground System: This switch usually has 5 wires (sometimes 4 wires). All of the wires and terminals rest @ 'ground' when the switch is not activated. One terminal becomes +12v (positive) only when the switch is activated. The switch sends a positive signal through the system and turns on the motor. The ground signal from the motor passes through the other side of the switch and goes to a chassis ground. There is no special relay in this circuit because the switches are hard-wired to handle the high current of the 'reversal rest @ ground' circuit required for most motor operations. Most Ford vehicles and most Chrysler vehicles use a Reversal Rest @ Ground circuit for door locks. Check the number of wires on the switch. If there are 4 or 5 wires, then the circuit is probably a reversal rest @ ground circuit. See diagram pg 11.

To determine which type is used in your vehicle, take a voltmeter and probe one of the output wires at the switch. Check the polarity with the switch pressed and without the switch pressed. Compare results with the chart below.

Door Lock Switch	Output Terminals		3 of Terminals
	Switch NOT Pressed	Switch Pressed	Typical # of Wires
Positive Pulse	No Voltage / Floats	+12 Volts	3 Wires
Negative Pulse	No Voltage / Floats	Ground	3 Wires
Reversal Rest@Ground	Ground	+12 Volts	5 Wires

****Please Note: The following diagrams / schematics are for reference only. The installer must verify that the circuit is properly wired with the correct gauge of wire, and properly fused the correct fuse size and type for the circuit.**

Installation: Electrical - Receiver Power & Ground

1) Install Power

Connect the Red wire to a constant +12v battery power source. Note: For best performance, run a clean +12v (14 gauge wire) directly from the battery or a fuse that is NOT supplying any power to motors, lights or any other type of high current device.

	Input	Wire Color	Max Input	Pin Position
Logic Power	+	Red	1 Amp (fused)	01
Relay Power	+	Purple	10 Amp (fused)	11
Ground	-	Black	1 Amp (fused)	03
Orange - Pin 4 - Not Used				

2) Install Ground

Connect the Black wire to chassis ground

A) Scrape all paint and grease away from the body frame.

A loose chassis ground connection WILL cause intermittent operation of receiver.

B) Clean the area using an alcohol based cleaner to remove paint chips and grease.

C) Crimp a #10, 3/16" ring terminal onto the black ground wire.

D) Insert the ring terminal and a #10, 3/16" star washer over a 10x3/4" hex head, self-tapping ground screw.

E) Tighten ground screw securely into clean frame area.

3) Install Outputs - Maximum output is 5 Amps per channel

A) Connect *only One* Channel output wire at a time to a relay or function which uses 5 Amps

B) Solder connections and protect with shrink tube or use an 18g insulated butt terminal.

4) Wiring Inspection

A) Check all wiring connections visually

B) Check the polarity of all wires

C) Tape off or remove all unused wires.

Channel	Output	Wire Color	Max Output	Pin Position
Channel 1	RR@G	Green / Black	5 Amp	09
	(+) positive	Green / Red	5 Amp	07
Channel 2	RR@G	Yellow / Black	5 Amp	08
	(+) Positive	Yellow / Red	5 Amp	06
Channel 3	(+) Positive	Tan	5 Amp	10

Notes:

1) Channels 1 and 2 are momentary outputs as long as the button is pressed.

2) Channels 3 and 4 are factory set as momentary outputs as long as the button is pressed. These outputs can be programmed as latching (push on - push off). Call the factory for program information at 1-800-294-2570

***Maximum output current 5 Amps. Over current will damage outputs.**

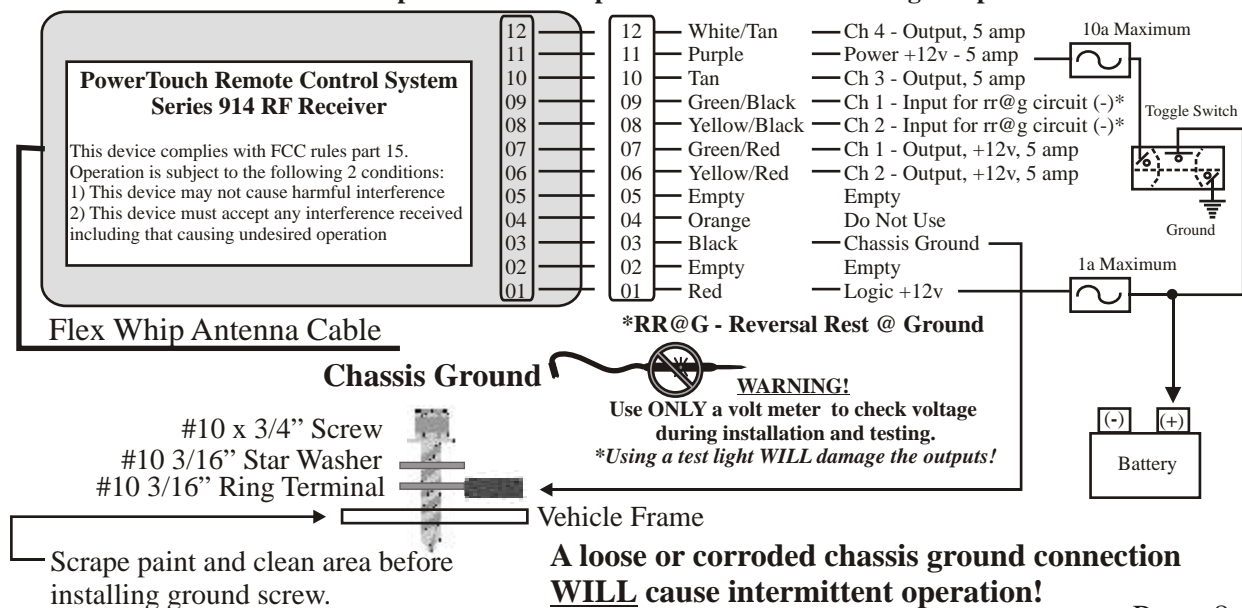

SETUP 1: Door Open Only, Buttons 1 and 2 Open Door

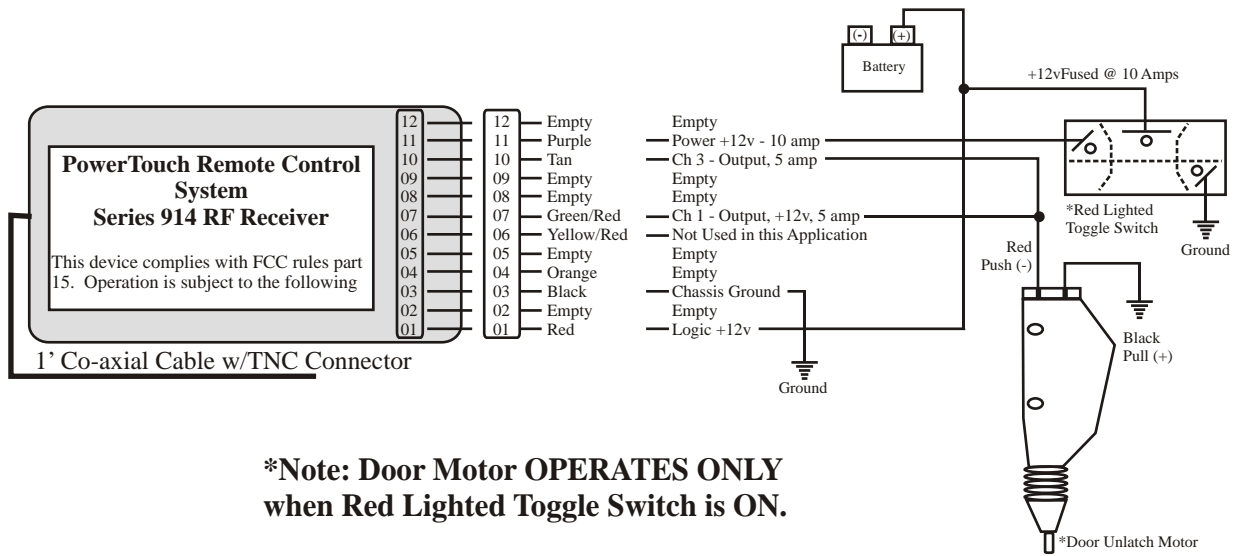

***Note: Door Motor OPERATES ONLY when Red Lighted Toggle Switch is ON.**

SETUP 2: Door Open and Door Lock / Door Unlock

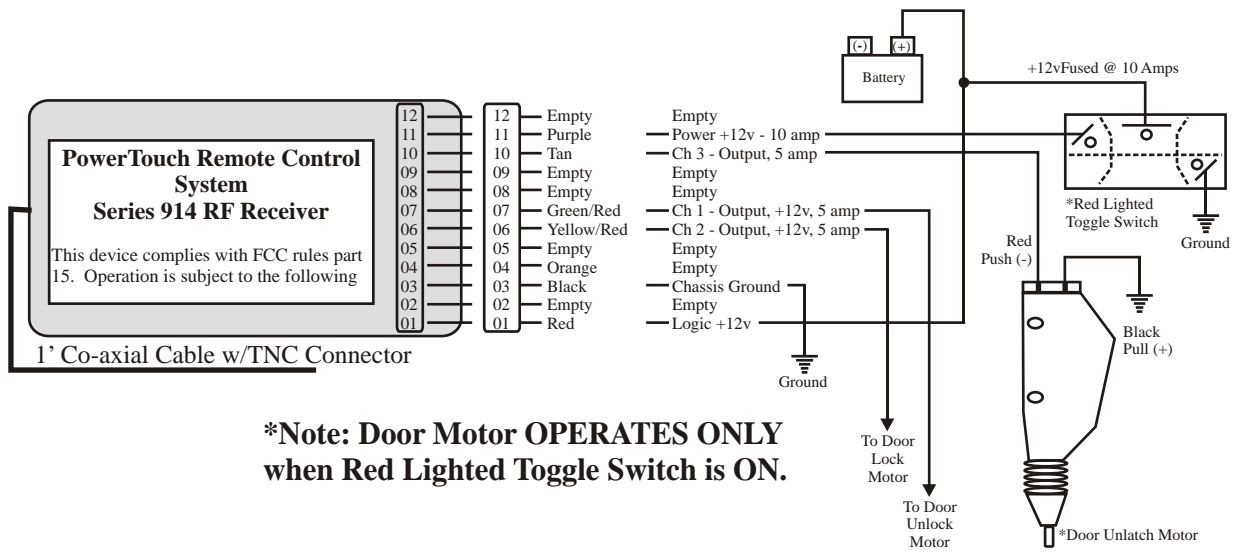

***Note: Door Motor OPERATES ONLY when Red Lighted Toggle Switch is ON.**

Installation: Electrical - Door Unlock / Lock Circuit

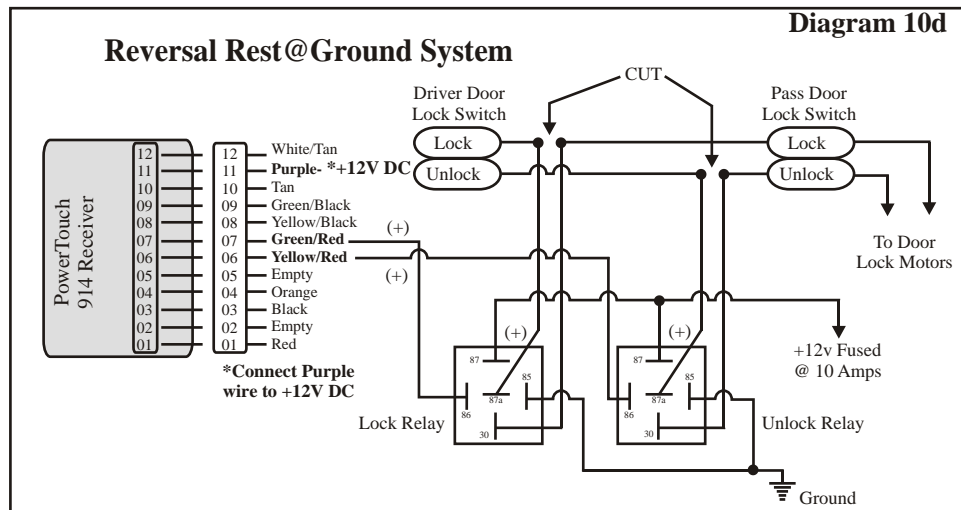
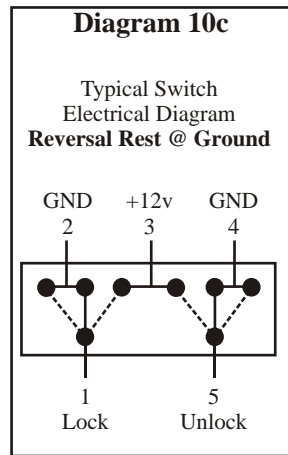
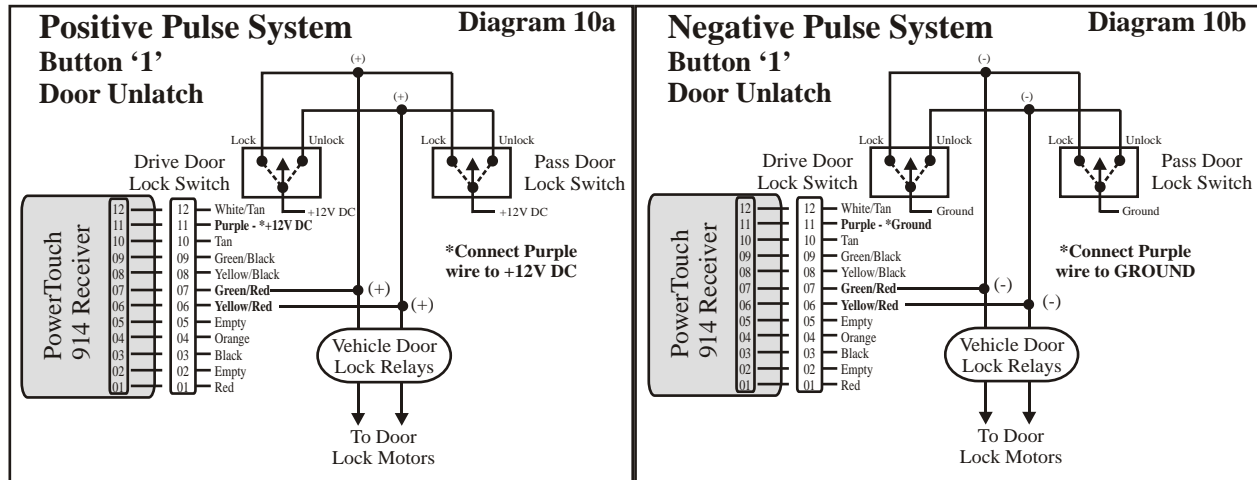

****Please Note:** Due to continually changing wire colors through-out the automotive industry, TouchTronics can NOT provide accurate wire color information on a consistent basis. Therefore, if the wire colors needed for installation are not known, please contact a local dealer and they should be able to provide any necessary information. Listed below are the currently known wire colors.

Vehicle	Year / Years	Unlock Wire Color	Lock Wire Color
Crown Victoria	1993 - 1999	Pink / Light Green	Pink / Yellow
Tahoe	1997 - 1998	Light Blue	White / Black or Black
Caprice	1993 - 1998	Light Blue	White / Black or Black
Jeep Grand Cherokee	1997 - 1998	Pink / Violet	Orange / Violet

Unlock / Lock Circuits used in vehicles:

Reversal Rest @ Ground - All wires are at a ground voltage until a switch is pressed, then the switched wire only is +12v. (1993 - 1998 Crown Victoria)

Positive Pulse Circuits - All wires are at a neutral voltage until a switch is pressed, then the switched wire becomes +12v. (1999 Crown Victoria & Chevy Caprice)

Installation: Safety Disable Switch

WARNING! If using any type of motor, such as a window motor or a door lock motor - add a Disable switch to prevent the door or window circuit from operating when vehicle is in motion. (Not provided in kit)

A disable switch should be installed in any application to deny operation of the motor when a vehicle is in motion. However, due to changes in automotive electrical design and the addition of computer controlled circuits, it is no longer advisable or safe to tap into or cut wires to disable automotive factory circuits. To overcome this problem, you must install an electro-mechanical switch which will determine gear position, thus safely disabling the circuit while the vehicle is in motion. Below are three options for installing a Safety Disable Switch.

Safety Disable Feature

Older models of Caprice and the Crown Victoria cars still have a Park/Neutral switch or output located near the steering column of the vehicle. However, many of the newer cars do not have an available output to sense the gear of the vehicle. The outputs that can sense the gear of the vehicle are logic level and directly connected to the computer, (ECM, Electronic Control Module). **If any wires or switches are attached to the ECM harness or computer outputs, the vehicle warranty may not be honored.**

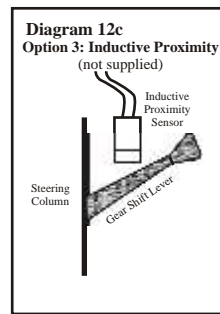
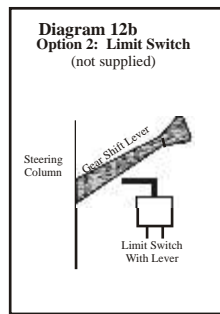

Installation: Electrical - Door Unlock / Lock Circuit

5) Install Door Lock Circuit

- A) Determine which type of door unlock circuit operates in the vehicle. See page 7 for a detailed explanation.
- B) Locate the lock and unlock wire color used in the vehicle. It is usually easiest to remove decorative panel around drivers switch and pop switch out of the door.
- C) Locate the switch and unlock motor in rear door.
- D) Determine if the wire colors in the switch match the wire color on the rear door lock motor for lock and unlock.
- E) CUT the wires between the rear door unlock switch and the rear door unlock motors. Choose a location that is easily serviced. (See diagram 12d)

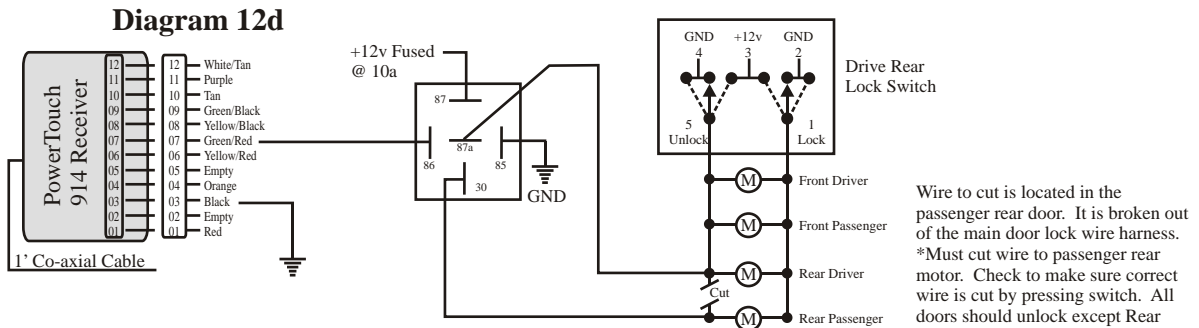

- F) Install a wire between relay terminal #87a and the cut wire going back to the switch.
- G) Install a wire between relay terminal #30 and the cut wire going to the motor.
- H) Reconnect power and test factory switch, then test button '1' to verify proper unlocking of rear passenger door.

Installation: Antenna

P/N: ANT.1TCBL
1' cable w/ TNC Connector

P/N: ANT.MSTFLEX
Flex Whip Antenna

914 Receiver

P/N: ANT.4TCBL
14' Cable w/TNC Connector
& Nipple Connector for Base

P/N: ANT.BSFLX
Mounting Base

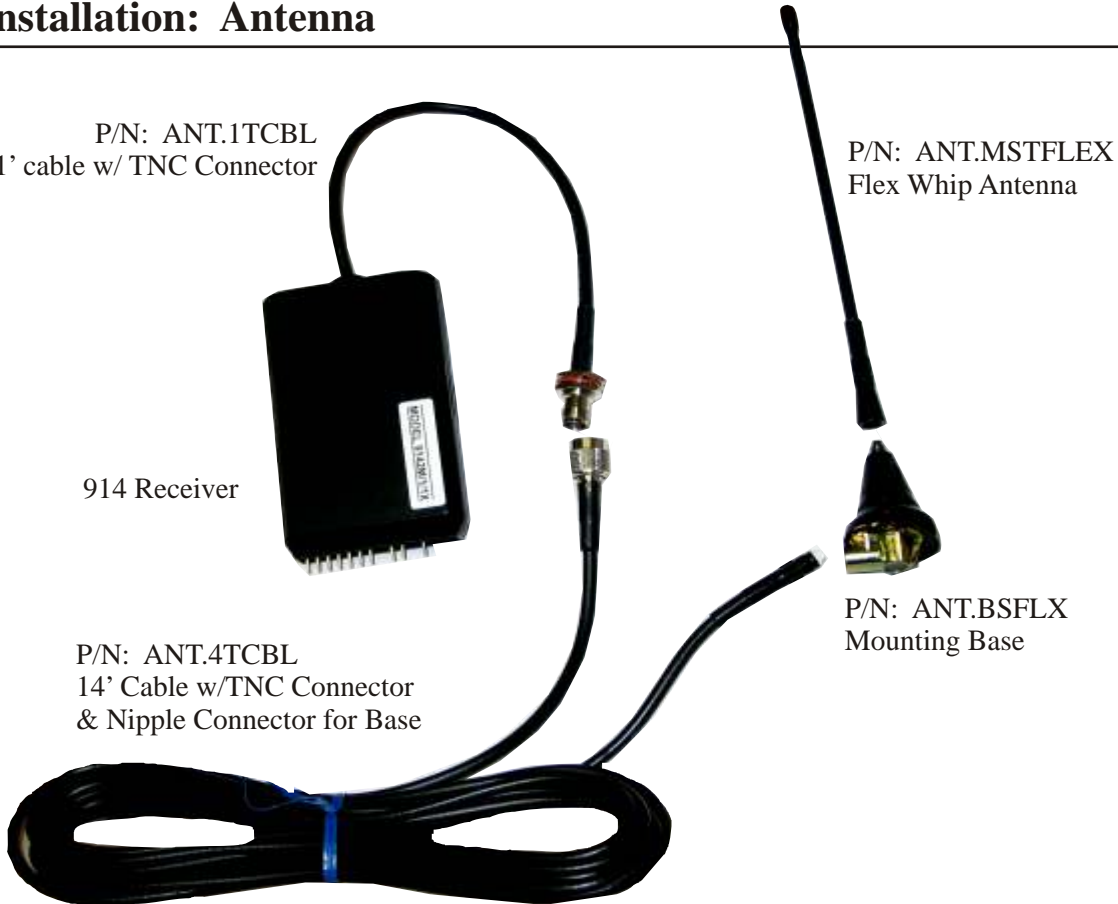

Antenna Installation

- 1) Choose location for mounting antenna; on roof of vehicle. Locate the antenna away from other antennas. Range can be reduced by competing RF signals generated by other RF antennas. To optimize the antenna range, change location of the antenna and / or re-tune the receiver to adjust for the interference.
- 2) Check range before drilling hole for antenna. The range should be 100 - 300 feet with all RF equipment 'On'.
- 3) Drill a 3/4" hole in the roof or trunk. Install antenna base into hole and screw connector onto base and tighten.
- 4) Route coaxial cable from receiver to antenna and install.
- 5) Check range again. Call TouchTronics Technical Help Line if there are any problems. See page 2 for contact information.

Receiver Tuning

- 1) Open receiver housing.
- 2) Locate the tuning pot (potentiometer) on the printed circuit board. The tuning post is a square silver metal box with a small hole on the top.
- 3) Using a plastic Allen wrench turn the pot 1/4 turn in either direction. Check range after each turn. Stop when optimum range is reached. The plastic Allen wrenches may be purchased at Radio Shack. They are RF tuning Allen wrenches. The green Allen wrench in the package is the correct size for tuning the pot.

Range

The range of your remote control will be determined by the location of the vehicle, and electromagnetic environment of the vehicle (the presence of competing radio signals) as well as the position of the receiving antenna in the vehicle. Standard range is between 75 feet and 150 feet, under good conditions the range can exceed 300 feet. A substantial increase in range can be achieved by holding the top edge of the transmitter against your chin while transmitting. Note: If both transmitters have short range, the problem could be competing signals from radio transmitters nearby, which will likely be temporary.

Installation: Final Test

- 1) Turn power toggle switch to Off
- 2) Replace battery power to vehicle
- 3) Power toggle switch should be Off - no red light
- 4) Test remote control buttons
 - a) Press vehicle unlock / lock switch
All doors or rear door SHOULD unlock / lock with corresponding switch press.
 - b) Press remote control button '1'
If connected to door unlock - All doors or rear door SHOULD NOT unlock
 - c) Press remote control button '2'
Door SHOULD NOT pop open
 - d) Press remote control buttons '1' & '2'
If connected to door lock - All doors or rear door SHOULD NOT lock
- 5) Turn power toggle switch to ON
- 6) Test remote control buttons again
 - a) Press vehicle unlock / lock switch
All doors or rear door SHOULD unlock / lock with corresponding button press.
 - b) Press remote control button '1'
If connected to door unlock - All doors or rear door SHOULD unlock
 - c) Press remote control button '2'
Door SHOULD pop open
 - d) Press remote control buttons '1' & '2'
If connected to door lock - All doors or rear door SHOULD lock
- 7) Place vehicle in gear
 - a) Press remote control button '2'
Door SHOULD NOT pop open if a disable switch is installed in the circuit.

Check the trouble shooting guide to determine reasons for any failures.

Trouble Shooting Guide - R.E.S.C.U.E. Remote Control System

If a component such as the receiver or transmitter fails; DO NOT remove the entire kit. Remove ONLY the failed component for repair or replacement.



Use a digital or analog voltmeter to check power and voltage! Do NOT use a test light!

Symptom	Possible Cause	Corrective Action									
<p>1.0 No output from one or more channels on remote control receiver</p>	<p>1.1 No signal from transmitter</p> <p>1.2 One or both of the outputs have failed</p> <p>1.3 Receiver outputs ok, but relays or equipment do not operate</p>	<p>1.1a Verify that transmitter is sending a signal and that transmitter is coded correctly. See symptom 4.00.</p> <p>1.1b Check status light on transmitters. Should be bright red.</p> <p>1.1c Check transmitter battery. Should be +12v and drop 0.2 - 0.3 volts when button is pressed.</p> <p>1.2a Press each transmitter button in sequence. While pressing button, <i>use only a voltmeter probe</i> to check each corresponding output</p> <table style="margin-left: 20px; border: none;"> <tr> <td style="padding-right: 20px;"><i>Channel 1</i></td> <td style="padding-right: 20px;"><i>Green/Red</i></td> <td><i>Button 1</i></td> </tr> <tr> <td><i>Channel 2</i></td> <td><i>Yellow/Red</i></td> <td><i>Button 1 & 2</i></td> </tr> <tr> <td><i>Channel 3</i></td> <td><i>Tan</i></td> <td><i>Button 2</i></td> </tr> </table> <p>1.2b If checking voltage, a positive signal is present when button is pressed and float when not pressed if input to wire is +12v.</p> <p>1.2c If outputs read nothing when pressed or not pressed, then the power supply is damaged.</p> <p>1.2d Send back to factory for repair or replacement.</p> <p>1.2e <i>Any of the above problems can be caused by a defective unit or damage by the customer from over-voltage, over-current or testing the inputs and outputs using a test light instead of a voltmeter.</i></p> <p>1.3 Check wire and equipment for problem.</p>	<i>Channel 1</i>	<i>Green/Red</i>	<i>Button 1</i>	<i>Channel 2</i>	<i>Yellow/Red</i>	<i>Button 1 & 2</i>	<i>Channel 3</i>	<i>Tan</i>	<i>Button 2</i>
<i>Channel 1</i>	<i>Green/Red</i>	<i>Button 1</i>									
<i>Channel 2</i>	<i>Yellow/Red</i>	<i>Button 1 & 2</i>									
<i>Channel 3</i>	<i>Tan</i>	<i>Button 2</i>									
Symptom	Possible Cause	Corrective Action									
<p>2.0 Signal transmitted and received, but no operation.</p>	<p>2.1 No signal from transmitter</p> <p>2.2 One or both of the outputs have failed</p> <p>2.3 Receiver has failed outputs</p>	<p>2.1 See section 4.00</p> <p>2.2a Check wire harness for loose connections or damaged wires or terminals.</p> <p>2.2b Check equipment for problem in motors or relays.</p> <p>2.3 Recheck section 1.0.</p>									

Trouble Shooting Guide - R.E.S.C.U.E. Remote Control System



**Use a digital or analog voltmeter to check power and voltage!
Do NOT use a test light**

Symptom	Possible Cause	Corrective Action
3.0 No power to remote control receiver	3.1 Logic ground or power connection to receiver has failed 3.2 Chassis ground connection has failed	3.1a Check logic ground (black wire) and logic power (red wire). Use a voltmeter probe when checking voltage. 3.1b If either ground or power is not present, then locate failure in wire harness and repair. 3.2a Check chassis ground connection, it should be clean and tight, no paint on metal, an external tooth star washer should be present, no rust or dirt in connection. 3.2b Chassis ground should be located on vehicle frame.
Symptom	Possible Cause	Corrective Action
4.0 No signal (code) being transmitted	4.1 Battery voltage low In transmitter 4.2 Transmitter is not sending a signal 4.3 Transmitter code is incorrect 4.4 Not all buttons send a signal when pressed	4.1 Check battery voltage. Replace battery if voltage is 11.5 volts or less. (Signal strength is dependent upon battery voltage.) 4.2 Place probe from voltmeter on battery (+) and (-) leads. Press any button, voltage should change by 0.2 to 0.3 volts if a signal is transmitted. Check both buttons. 4.3a If transmitter is sending a signal and no signal is being received, re-code transmitter. 4.3b Send back to factory for re-coding. 4.4 If a signal is not transmitted on all buttons, send back to factory for repair or replacement.
Symptom	Possible Cause	Corrective Action
5.0 Poor range 0' to 25' (pulsating 0' to 25')	5.1 Antenna damaged or grounded	5.1a Check antenna placement, it should not be touching any metal or tinted glass. 5.1b It should not be closer than 6' to any motors or relays. 5.1c If it is coiled, then stretch it out and place near a window. 5.1d If antenna is cut or damaged, send back to factory for repair. 5.1e <i>NOTE: Antenna can NOT be shortened or altered in any way</i>

Trouble Shooting Guide - R.E.S.C.U.E. Remote Control System

Symptom	Possible Cause	Corrective Action
5.0 Poor range 0' to 25' (pulsating 0' to 25')	5.2 Receiver installed in poor locations such as near door or lift motor	5.2a Disconnect door and / or ramp motor and recheck range. 5.2b If range is ok, then 'electrical noise' from motors is causing interference with RF signal. 5.2c Move receiver and antenna a minimum of 6 feet from the motors. 5.2d If moving receiver 6 feet does not improve, an external antenna may be required to boost signal.
	5.3 Receiver logic power input is exposed to radiated noise from wire harness or motors	5.3a Disconnect receiver logic power input from main wire harness. 5.3b Run new wire from vehicle battery to red wire.
	5.4 Receiver logic ground is exposed to radiated noise from wire harness or motors	5.4a Disconnect receiver logic ground input from main wire harness. 5.4b Remove black wire on receiver from wire harness and install on the vehicle frame for a new chassis ground or vehicle battery. 5.4c Remove any paint or residue from metal, use an external tooth star washer and tighten new chassis ground terminal securely to vehicle frame.
	5.5 Transmitter 12-volt battery is low	5.5 Replace battery if voltage is 11.5 volts or below.
	5.6 Out of 25 foot range	5.6 Move closer to the vehicle.
	5.7 Interference	5.7a Electromagnetic interference (EMI) caused by any radio frequency (RF) nearby, motors, welding equipment, relays, etc. May be in close proximity to receiver / transmitter. 5.7b Move closer to antenna or move vehicle out of range of EMI caused by radio frequency, welding equipment, as this is a temporary problem. 5.7c If EMI is caused by relays, door motors or lift motors then the receiver must be moved or shielded or the EMI noise diverted to ground. Call the factory for details.
	5.8 Component of receiver damaged or defective	5.8 Send back to factory for repair or replacement.
	5.9 Other equipment installed in vehicle causing voltage drop when initially turning on	5.9 Remove all other equipment from logic ground and power.

TouchTronics, Inc. Warranty Policies and Procedures

The following revised warranty procedures will be implemented and effective March 1, 2002.

- 1) All products will now be shipped with an individual bar code attached.
- 2) The bar code will include some or all of the following information.
 - A) Date of Manufacture
 - B) Serial Number
 - C) Private Code
 - D) Part Number
- 3) Warranty Cards are no longer required to be eligible to receive technical support and service.
- 4) Each individual product is warranted under the TouchTronics Limited Warranty program for 1 full year from date of purchase or a *maximum* of 2 years from the date of manufacture.
- 5) No product will be covered under the TouchTronics Limited Warranty program that has a manufacture date older than 2 years.
- 6) To receive technical support or warranty service, simply call our technical support center during regular business hours.
- 7) To enable our technical support staff to better serve you, please have the following information available when you call.

Date Of:	
Manufacture	
Purchase	
Installation	

Vehicle Information:	
Dealer Name	
Dealer Phone	
Make / Model	

Product Information:	
Part Number	
Serial Number	
Private Code	

Please fill in all pertinent information at the time of purchase or installation

Limited One (1) Year Warranty

Section One

Seller will warrant any product originally manufactured or assembled and sold by seller for a period of *up to TWO YEARS* (24 months) from the original date of manufacture or **ONE YEAR** (12 months) from the original retail sale or O.E.M. in-service date.

Section Two

The following are in lieu of all warranties; expressed; implied; or statutory, including but not limited to, any implied warranty of merchantability of fitness for a particular purpose and of any other warranty obligation on the part of seller. Seller, except as otherwise hereinafter provided, warrants the goods against faulty workmanship or the use of defective materials for a period of *up to TWO YEARS* (24 months) from the original date of manufacture or **ONE YEAR** (12 months) from the original retail or O.E.M. in-service date.

Sellers sole and exclusive liability shall be (at sellers option) to repair; replace; or credit buyer for such goods which are returned by buyer during the applicable warranty period set forth above, provided that (I) seller is promptly notified in writing or phone upon discovery by buyer that such goods failed to conform and an explanation of any alleged deficiencies, (II) such goods are returned to seller, (III) sellers examination of such goods shall disclose that such alleged deficiencies actually exist and were not caused by accident, misuse, neglect, alteration, improper installation, unauthorized repair or improper testing. If seller elects to repair or replace such goods, seller shall have a reasonable time to make such repairs or replace such goods.

Sellers warranties as herein above set forth shall not be enlarged, diminished, or affected by, and no obligation or liability shall arise or grow out of, sellers rendering of technical advice or service.

Damage to products caused by the customer or during installation cannot be claimed under this warranty. All devices returned that are not covered under the sellers warranty policy, will be charged a minimum of \$25.00 for evaluation plus additional charges for components and labor to repair the device not to exceed the original selling price. Seller considers the following to be typical examples of customer or installation damage: burned or broken traces on the printed circuit board, burned or damaged components, dirt or water residue on the printed circuit board or inside the case, modifications by the customer, broken cases or housings and dead batteries

Section Three

A return material authorization number (RMA) must be issued by seller before any product is returned for evaluation or repair. Warranty repairs must be completed at authorized repair facilities.

Warrantypolicy1 rev a.doc
01.01.03 rev a
09.30.98 rev int
Effective January 1, 2003

This space left blank intentionally. May be used for installation notes or drawings.